

# OPERATION & PARTS MANUAL



***ESSICK* SERIES**  
**MODEL EM-900SD** (CE)  
**PLASTER/MORTAR MIXER**  
**(HATZ DIESEL ENGINE)**

Revision #1 (07/02/04)

**THIS MANUAL MUST ACCOMPANY  
THE EQUIPMENT AT ALL TIMES.**

# **HERE'S HOW TO GET HELP**

PLEASE HAVE THE MODEL AND SERIAL  
NUMBER *ON-HAND* WHEN CALLING

## **UNITED STATES**

### ***MULTIQUIP CORPORATE OFFICE***

18910 Wilmington Ave.

Carson, CA 90746

Contact: mq@multiquip.com

Tel. (800)-421-1244

Fax (310)-537-3927

## **MEXICO**

### ***MQ CIPSA***

Carr. Fed. Mexico-Puebla KM 126.5

Momoxpan, Cholula, Puebla 72760 Mexico

Contact: pmastretta@cipsa.com.mx

Tel. (52) 222-225-9900

Fax (52) 222-285-0420

## **UNITED KINGDOM**

### ***MULTIQUIP (UK) LIMITED HEAD OFFICE***

Hanover Mill, Fitzroy Street,

Ashton-under-Lyne,

Lancashire OL7 0TL

Contact: kcassell@multiquip.com.uk

Tel. 0161 339 2223

Fax 0161 339 3226

## **CANADA**

### ***MULTIQUIP***

4110 Industriel Boul.

Laval, Quebec, Canada H7L 6V3

Contact: jmartin@multiquip.com

Tel. (450) 625-2244

Fax (450) 625-8664

## **BRAZIL**

### ***MULTIQUIP***

Av. Evandro Lins e Silva, 840 - grupo 505

Barra de Tijuca - Rio de Janeiro

RJ CEP 22631-470

Contact: cnavarro@multiquip.com.br, srentes@multiquip.com.br

Tel. 011-55-21-3433-9055

Fax 011-55-21-3433-9055

© COPYRIGHT 2004, MULTIQUIP INC.

Multiquip Inc, the MQ logo and the Essick logo are registered trademarks of Multiquip Inc. and may not be used, reproduced, or altered without written permission. All other trademarks are the property of their respective owners and used with permission.

This manual **MUST** accompany the equipment at all times. This manual is considered a permanent part of the equipment and should remain with the unit if resold.

The information and specifications included in this publication were in effect at the time of approval for printing. Illustrations are based on the *EM-900SD (CE)*. Multiquip Inc. reserves the right to discontinue or change specifications, design or the information published in this publication at any time without notice and without incurring any obligations.

**To find the latest revision of this  
publication, visit our website at:  
[www.multiquip.com](http://www.multiquip.com)**



## **Multiquip — Plaster/Mortar Mixer Model EM-900SD CE**

Here's How To Get Help .....	2
Table Of Contents .....	3
Safety Message Alert Symbols .....	4-5
Operation and Safety Decals .....	6-7
Specification (Noise and Vibration) .....	8
Specifications (Mixer/Engine) .....	9
Rules For Safe Operation .....	10-11
General Information .....	12
Engine Components .....	13
Mixer Controls and Components .....	14
Paddle Blade Adjustment .....	15
Inspection .....	16-17
Initial Start-up .....	18
Maintenance .....	19-20
Troubleshooting (Engine) .....	21
Troubleshooting (Engine/Mixer) .....	22
Explanation Of Codes In Remarks Column .....	24
Suggested Spare Parts .....	25
Nameplate and Decals .....	26-29
Mixing Drum Assembly .....	30-31
Paddle Shaft Assembly .....	32-33
Cabinet Assembly .....	34-35
Frame Assembly .....	36-37

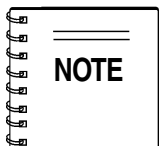
## **Engine**

Hatz Engine Assembly .....	38-39
----------------------------	-------

## **Transmission**

Transmission Assembly .....	40-41
-----------------------------	-------

Terms and Conditions Of Sale — Parts .....	42
--	----



*Specification and part number  
are subject to change without  
notice.*

# EM-900SDCE MIXER — SAFETY MESSAGE ALERT SYMBOLS

## FOR YOUR SAFETY AND THE SAFETY OF OTHERS!

Safety precautions should be followed at all times when operating this equipment. Failure to read and understand the Safety Messages and Operating Instructions could result in injury to yourself and others.

### NOTE

This Owner's Manual has been developed to provide complete instructions for the safe and efficient operation of Multiquip's EM-900SDCE mixer. For specific engine operating questions, please refer to the engine manufacturers instructions for data relative to its safe operation.

**Before using this MIXER, ensure that the operating individual has read and understands all instructions in this manual.**

## SAFETY MESSAGE ALERT SYMBOLS

The three (3) Safety Messages shown below will inform you about potential hazards that could injure you or others. The Safety Messages specifically address the level of exposure to the operator, and are preceded by one of three words: **DANGER**, **WARNING**, or **CAUTION**.

### **DANGER**

You **WILL** be **KILLED** or **SERIOUSLY INJURED** if you **DO NOT** follow these directions.

### **WARNING**

You **CAN** be **KILLED** or **SERIOUSLY INJURED** if you **DO NOT** follow these directions.

### **CAUTION**

You **CAN** be **INJURED** if you **DO NOT** follow these directions.

Potential hazards associated with MIXER operation will be referenced with Hazard Symbols which appear throughout this manual, and will be referenced in conjunction with Safety Message Alert Symbols.

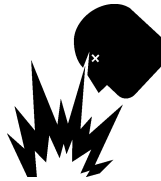
## HAZARD SYMBOLS

### **Lethal Exhaust Gases**



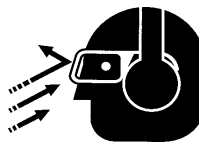
Engine exhaust gases contain poisonous carbon monoxide. This gas is colorless and odorless, and can cause death if inhaled. **NEVER** operate this equipment in a confined area or enclosed structure that does not provide ample free flow air.

### **Explosive Fuel**



**Diesel** fuel is extremely flammable, and its vapors can cause an explosion if ignited. **DO NOT** start the engine near spilled fuel or combustible fluids. **DO NOT** fill the fuel tank while the engine is running or hot. **DO NOT** overfill tank, since spilled fuel could ignite if it comes into contact with hot engine parts or sparks from the ignition system. Store fuel in approved containers, in well-ventilated areas and away from sparks and flames. **NEVER** use fuel as a cleaning agent.

### **Burn Hazards**

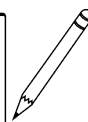
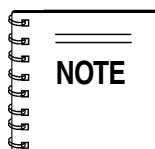


Engine components can generate extreme heat. To prevent burns, **DO NOT** touch these areas while the engine is running or immediately after operations. Never operate the engine with heat shields or heat guards removed.

### **Rotating Parts**



**NEVER** operate mixer with covers, or guards removed. Keep fingers, hands, hair and clothing away from all moving parts to prevent injury.



This **MIXER**, other property, or the surrounding environment could be damaged if you do not follow instructions.

# EM-900SDCE MIXER — SAFETY MESSAGE ALERT SYMBOLS



## Accidental Starting



OFF

**ALWAYS** make sure the engine is turned **OFF** before servicing the engine or equipment.



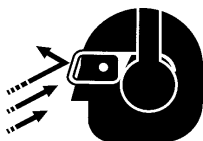
## Respiratory Hazard



**ALWAYS** wear approved respiratory protection.



## Sight and Hearing hazard

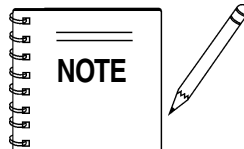


**ALWAYS** wear approved eye and hearing protection.



## Equipment Damage Messages

Other important messages are provided throughout this manual to help prevent damage to your mixer, other property, or the surrounding environment.



This mixer, other property, or the surrounding environment could be damaged if you do not follow instructions.

# EM-900SDCE MIXER — OPERATION AND SAFETY DECALS

## Machine Safety Decals

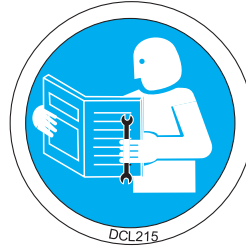
The Multiquip EM-900SDCE mixer is equipped with a number of safety decals (see below and on the preceding page). These decals are provided for operator safety and maintenance information. The illustration below shows these decals as they appear on the machine. If any of these decals become unreadable, replacements can be obtained from your dealer.



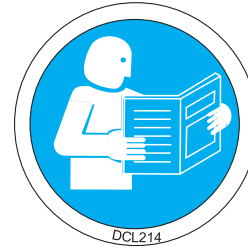
P/N DCL210



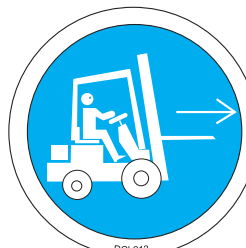
P/N DCL211



P/N DCL215



P/N DCL214



P/N DCL213



P/N DCL212



P/N DCL218



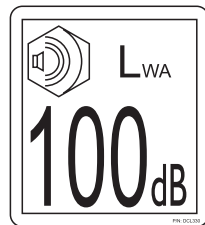
P/N DCL219



P/N DCL216



P/N DCL217



P/N DCL330

**MQ MULTIQUIP**

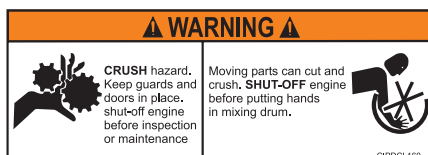
P/N DCL228 (LARGE)

**MQ MULTIQUIP**

P/N DCL227 (SMALL)



P/N DCL224



P/N CIPDCL160



P/N DCL260

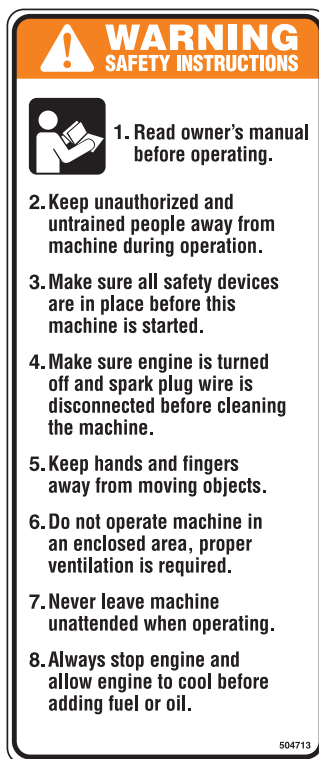
# EM-900SDCE MIXER — OPERATION AND SAFETY DECALS



P/N DCL225



P/N DCL226



P/N 504713



P/N 35137



P/N 13118



CONTACT MQ  
PARTS DEPT.



P/N EM948630



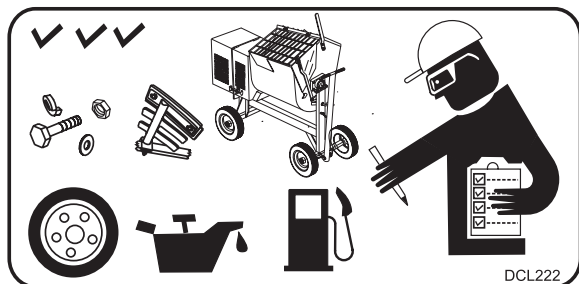
P/N 11092



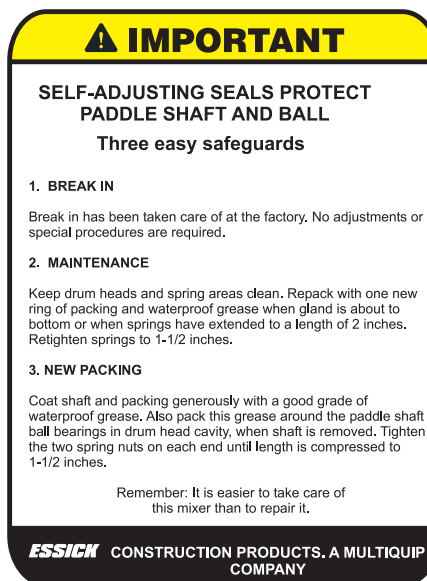
P/N 948013



P/N 948012



P/N DCL222



P/N 948121

# EM-900SDCE MIXER — SPECIFICATIONS (NOISE AND VIBRATION)



## EC Declaration of Conformity

In accordance with EN 45014:1998

Equipment Diesel powered Mortar/Plaster Mixer

Model Name/Number EM-900SDCE

In accordance with the following Directive(s):

98/37/EC The Machinery Directive

has been designed and manufactured to the following specifications:

BS EN 292-2:1991 Safety of Machinery- General Requirements

prEN12152:1995 Machinery and Plant for the Preparation of Mortar

BS EN1679-1:1998 Compression Ignition Engines

### **Noise Values**

The sound level according to appendix 1, paragraph 1.7.4.f of the EC machinery regulation is defined as:

Sound pressure level at the operator's stand:  $L_{pA} = 81.1 \text{ db (A)}$

Sound capacity level:  $L_{WA} = 100.0 \text{ db (A)}$

These sound values were determined according to ISO EN 3744:1994 (E) and 2000/14/EL



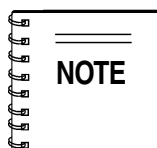
# EM-900SDCE MIXER — SPECIFICATIONS

**Table 1. EM-900 SDCE Mixer Specifications**

Capacity	248 liters (9 cu. ft.)
Weight (less wheels)	471 Kg. (1,038) lbs.
L x W x H	180 x 127 x 150 cm (71 x 50 x 59 in)
Drive	Transmission, Mechanical
Dump Action	Manual

**Table 2. HATZ Engine Specifications**

Model	1B30
Type	Air-cooled 4- stroke DIESEL engine
Combustion System	Direct Injection
Number Of Cylinders	1
Horsepower	6.8 HP
Displacement	347 cm <sup>3</sup>
Oil Capacity	1 liter (1.05 qt.)
Engine Oil Type	CCMC - D4 - D5 - PD2 or API - CD - CE -CF - CG OR SHPD
Type Fuel	EN 590 - DIN 51601 BS 2869 A1/A2 - ASTM D 975-1D/2D
Type Air Cleaner	Dry Element
Starting Method	Recoil Start
Weight (includes fuel tank, air cleaner, exhaust silencer, and recoil starter).	38 kg. (83.77 lbs.)



In accordance with our established policy of constant improvement, we reserve the right to amend these specifications at any time without notice.

# EM-900SDCE MIXER — RULES FOR SAFE OPERATION

## CAUTION

Failure to follow instructions in this manual may lead to serious injury or even death! This equipment is to be operated by trained and qualified personnel only! This equipment is for industrial use only.

The following safety guidelines should always be used when operating the EM-900SD CE mixer:

### GENERAL SAFETY

- **DO NOT** operate or service this equipment before reading this entire manual.



- This equipment should not be operated by persons under 18 years of age.

- **NEVER** operate this equipment without proper protective clothing, shatterproof glasses, steel-toed boots and other protective devices required by the job.



- **NEVER** operate this equipment when not feeling well due to fatigue, illness or taking medicine.



- **NEVER** operate this equipment under the influence of drugs or alcohol.



- **NEVER** use accessories or attachments, which are not recommended by Multiquip for this equipment. Damage to the equipment and/or injury to user may result.

- Manufacture does not assume responsibility for any accident due to equipment modifications.

- Whenever necessary, replace nameplate, operation and safety decals when they become difficult read.

- **ALWAYS** check the machine for loosened threads or bolts before starting.

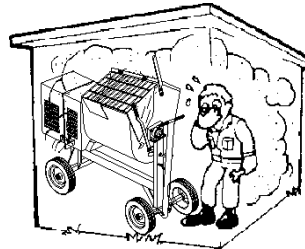
- **NEVER** touch the hot exhaust manifold, muffler or cylinder. Allow these parts to cool before servicing engine or mixer.



- **High Temperatures** – Allow the engine to cool before adding fuel or performing service and maintenance functions. Contact with *hot* components can cause serious burns.

- The engine section of this mixer requires an adequate free flow of cooling air. Never operate the mixer in any enclosed or narrow area where free flow of the air is restricted. If the air

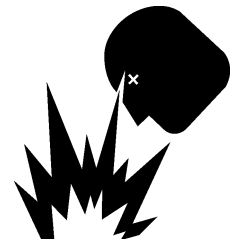
flow is restricted it will cause serious damage to the mixer or engine and may cause injury to people. Remember the mixer's engine gives off **DEADLY** carbon monoxide gas.



- **ALWAYS** refuel in a well-ventilated area, away from sparks and open flames.

- **ALWAYS** use extreme caution when working with **flammable** liquids. When refueling, **stop the engine** and allow it to cool. **DO NOT** smoke around or near the machine. Fire or explosion could result from fuel vapors, or if fuel is spilled on a hot engine.

- **NEVER** operate the mixer in an explosive atmosphere or near combustible materials. An explosion or fire could result causing severe *bodily harm or even death*.



- Topping-off to filler port is dangerous, as it tends to spill fuel.

# EM-900SDCE MIXER — RULES FOR SAFE OPERATION

## GENERAL SAFETY

- Stop the engine when leaving the mixer unattended.
- Block the unit when leaving or when using on a slope.
- Maintain this equipment in a safe operating condition at all times.
- **ALWAYS** stop the engine before servicing, adding fuel and oil.
- **NEVER** Run engine without air filter. Severe engine damage may occur.
- **ALWAYS** service air cleaner frequently.
- **ALWAYS** be sure the operator is familiar with proper safety precautions and operations techniques before using mixer.
- **ALWAYS** store equipment properly when it is not being used. Equipment should be stored in a clean, dry location out of the reach of children.
- **NEVER** use accessories or attachments, which are not recommended by Multiquip for this equipment. Damage to the equipment and/or injury to user may result.
- **ALWAYS** read, understand, and follow procedures in Operator's Manual before attempting to operate equipment.
- **CAUTION!** must be exercised while servicing this equipment. Rotating and moving parts can cause injury if contacted.
- Keep all inexperienced and unauthorized people away from the equipment at all times.
- Unauthorized equipment modifications will void all warranties.
- Check all fasteners periodically for tightness.
- Stop the engine before allowing anybody's hands in the mixing drum.
- **NEVER** pour or spray water over the engine.
- **ALWAYS** stand clear of dump handle when mixer is in operation. Any binding of material between the mixer blades and drum will cause drum and handle to quickly move in the discharge position.
- **NEVER** operate the mixer with the grate (grill) *open* or *removed*.

## CAUTION

**DO NOT** operate this equipment unless all guards and safety devices are attached and in place.

## Maintenance Safety

- **NEVER** lubricate components or attempt service on a running machine.
- **ALWAYS** allow the machine a proper amount of time to cool before servicing.
- Keep the machinery in proper running condition.
- Fix damage to the machine immediately and always replace broken parts.
- Dispose of hazardous waste properly. Examples of potentially hazardous waste are used motor oil, fuel and fuel filters.
- **DO NOT** use food or plastic containers to dispose of hazardous waste. **Emergencies**

## Emergencies

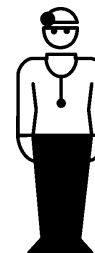
- **ALWAYS** know the location of the nearest *fire extinguisher*.



- **ALWAYS** know the location of the nearest and *first aid kit*.



- In emergencies *always* know the location of the nearest phone or *keep a phone on the job site*. Also know the phone numbers of the nearest *ambulance*, *doctor* and *fire department*. This information will be invaluable in the case of an emergency.



# EM-900SDCE MIXER — GENERAL INFORMATION

## GENERAL

Multiquip's EM-900SD CE series plaster and mortar mixer is shipped completely assembled and has been factory tested.

The drum batch capacity of this mixer is between 6 and 7 bags using DIN 1164 size bags (25 kg/bag). With proper care, it will give continuous service year-after-year.

This mixer is powered by a **6.8 HP HATZ Model 1B30** diesel engine. The power from the engine is transmitted via the clutch/reduction assembly directly to the paddle shaft. Therefore providing high mixer torque and eliminating V-belts.

## BEFORE STARTING

Before starting the engine, read the engine owners manual and thoroughly understand the safety information.



## OIL LEVELS

Be sure to check the oil levels in the engine and engine reduction unit before starting the unit.

## HARDWARE

Check all hardware on the mixer before starting. Periodically inspect all hardware. Loose hardware can contribute to early component failure and poor performance. Use Table 3 (Torque Chart) as a general guideline and keep all hardware tight.

## DIESEL ENGINE CARE

For care and operation of the **HATZ** diesel engine, refer to the engine manufacturer's operating instructions furnished with the engine. We recommend draining and refilling the engine crankcase at least every thirty hours of operation. Check the engine oil level daily.

Table 3. Torque Chart

Hardware Diameter	Torque
7.94 mm (5-16"- 18)	117 kgf/m <sup>2</sup> (24 ft-lbs.)
(9.53 mm) (3/8"- 24)	180 kgf/m <sup>2</sup> (37 ft-lbs.)
12.70 mm (1/2"- 13)	190 kgf/m <sup>2</sup> (39 ft-lbs.)
12.70 mm (1/2"- 13) Grade 8	439 kgf/m <sup>2</sup> (90 ft-lbs.)

# EM-900SDCE MIXER — ENGINE COMPONENTS

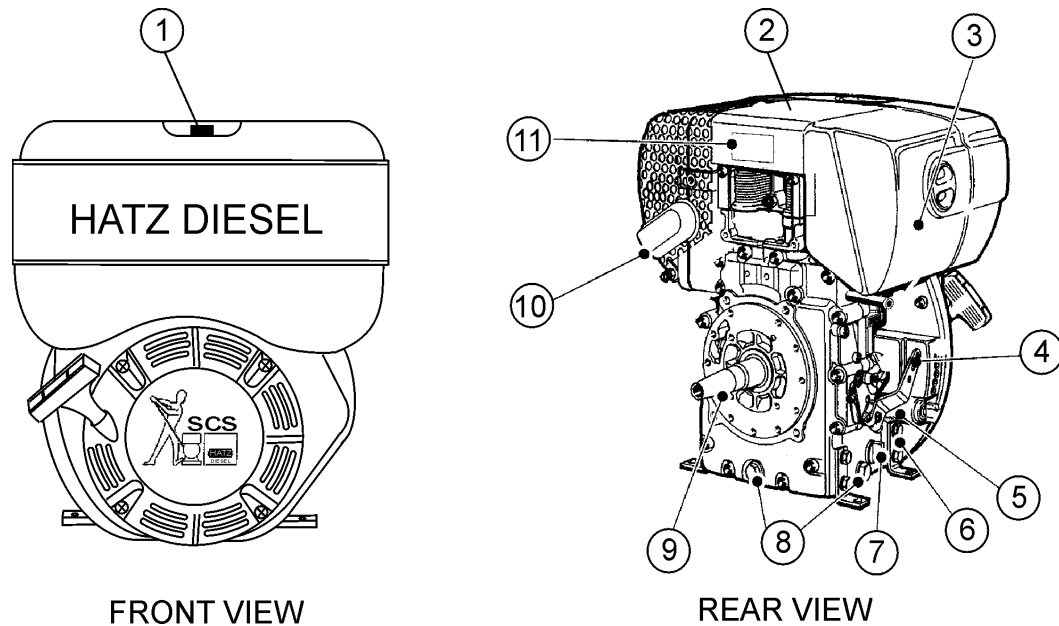


Figure 1. Basic Engine Components

## INITIAL SERVICING

The engine (Figure 1) must be checked for proper lubrication and filled with fuel prior to operation. Refer to the manufacturers Engine manual for instructions & details of operation and servicing.

1. **Fuel Filler Cap/Fuel tank** – Pull this latch to add *diesel* fuel to the tank. After refueling, always make sure the fuel cap is latched properly. **DO NOT** over fill. For additional information refer to engine owner's manual.

## DANGER

Adding fuel to the tank should be accomplished only when the engine is stopped and has had an opportunity to cool down. In the event of a fuel spill, **DO NOT** attempt to start the engine until the fuel residue has been completely wiped up, and the area surrounding the engine is dry.

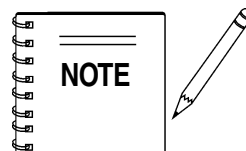
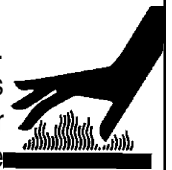


2. **Engine Lifting Straps/Cover** – Remove the air cleaner cover, then lift this cover (the one with decals on it) to gain access to the engine lifting straps.
3. **Air Cleaner/Cover** – Prevents dirt and other debris from entering the fuel system. Remove wing-nut on side of air filter cover to gain access to filter element.
4. **Speed Control Lever** – This lever is connected to the throttle control which is located on the side of the engine compartment cover. Use this lever to control engine speed.
5. **Dip Stick** – Remove dipstick to determine if the engine oil level is low. If low add oil as specified in Table 4, page 18.

6. **Engine Motor Mounts** – Attach these engine mounts to the mixer frame. Tighten securely.
7. **Oil Filter** – Remove this bolt to gain access (internal) to the engine oil filter. Service the oil filter as recommended in the maintenance section of this manual.
8. **Oil Drain Plugs** – There are two oil drain plugs, one is underneath the flywheel, the other on the side of the engine. Remove these plugs to drain engine oil from the engine.
9. **Crankshaft** – Connect this shaft to the input of the transmission.
10. **Muffler** – Used to reduce noise and emissions.
11. **Nameplate** – Contains information about the engine.

## WARNING

Engine components can generate extreme heat. To prevent burns, **DO NOT** touch these areas while the engine is running or immediately after operating. **NEVER** operate the engine with the muffler removed.



## NOTE

Operating the engine without an air filter, with a damaged air filter, or a filter in need of replacement will allow dirt to enter the engine, causing rapid engine wear.

# EM-900SDCE MIXER — CONTROLS AND COMPONENTS

1. **Engine Cover** — Lift this cover to gain access to the engine compartment.
2. **Clutch Engagement Lever** — Push the clutch lever forward, toward the tow end of the mixer to engage clutch. Once the clutch is engaged the paddle shaft will begin to rotate. To disengage clutch pull the clutch backwards towards the engine.
3. **Throttle Control/Stop Switch** — Pull all the way out to achieved maximum engine RPM's. To stop the engine, push the RED stop button inwards.
4. **Safety Grill** — Provided for operator safety. This safety grill is designed to keep hands and solid objects out of the mixing drum when in use. This grill should be closed at all times when mixer is in use. **DO NOT** remove the grill or grill opening bar. Keep the grill clean by washing it down daily.
5. **Bag Cutter**— This feature allows compound mixing bags to be opened easily, therefore allowing the contents of the bag to fall directly into the mixing drum.
6. **Dump Handle** — Pull this handle downward to dump the contents of the drum. Push the handle upward to return the drum to its vertical position.
7. **Transport Handle** — Use this T-handle to transport the mixer. **NEVER** tow this mixer on a highway.
8. **Pivot Point/Zerk Fitting** — There is, on each end of the mixing drum a zerk grease fitting. These fittings lubricate the dumping mechanism. Lubricate both fittings at least twice a week.
9. **Dump Handle Release Pin** — Pull this pin outward (spring loaded) to release the drum, then pull down on the dump handle to place the drum in the dump position. When drum is in dump position, pin will automatically lock drum.
10. **Tires** — This unit employs the use of solid rubber tires.
11. **Transport Bar Release Latch** — To transport the mixer un-hook the transport bar from the latch. When work is being performed **ALWAYS** have the transport bar latched in the upright position.
12. **Safety Grill Lock Handle** — To prevent injury to hands and arms, the safety grill should **ALWAYS** be locked when the mixing of plaster or mortar is required. Also when transporting the mixer the safety grill should be locked. The safety grill should only be un-locked when cleaning of the blades and drum is required.
13. **Steel Mixing Drum** — Mixing materials such as concrete, mortar, plaster are to be placed into this drum for mixing. Always clean the drum after each use.
14. **Mixing Paddles** — Used in the mixing of material. This unit uses four different types of paddles to provide a fast uniform mix.
15. **Bunjee Latch** — Use this latch to secure the engine compartment cabinet.
16. **Fork Lift Pocket** — When lifting of the mixer is required, use these fork lift pockets to lift the mixer. Remember to insert the forks of the fork lift a minimum of 60.96 cm. (24 inches) into the mixer's fork lift pocket.

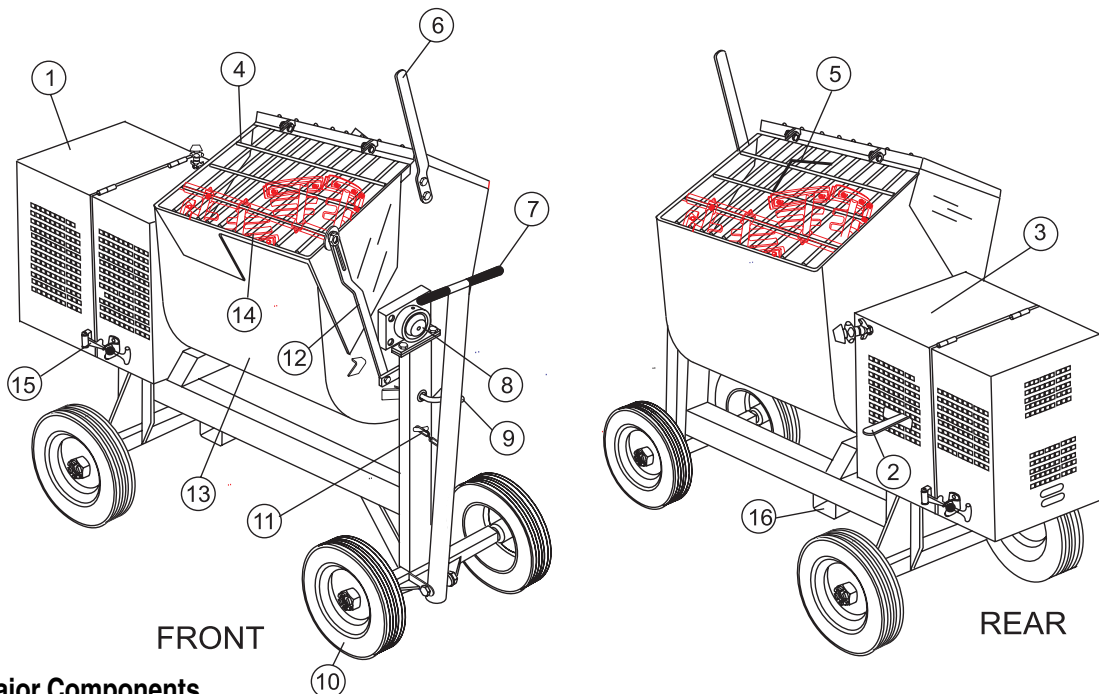


Figure 2. Mixer Major Components

# EM-900SDCE MIXER — PADDLE BLADE ADJUSTMENT

Figure 3 illustrates the paddle blade adjustment (*steel drum*).

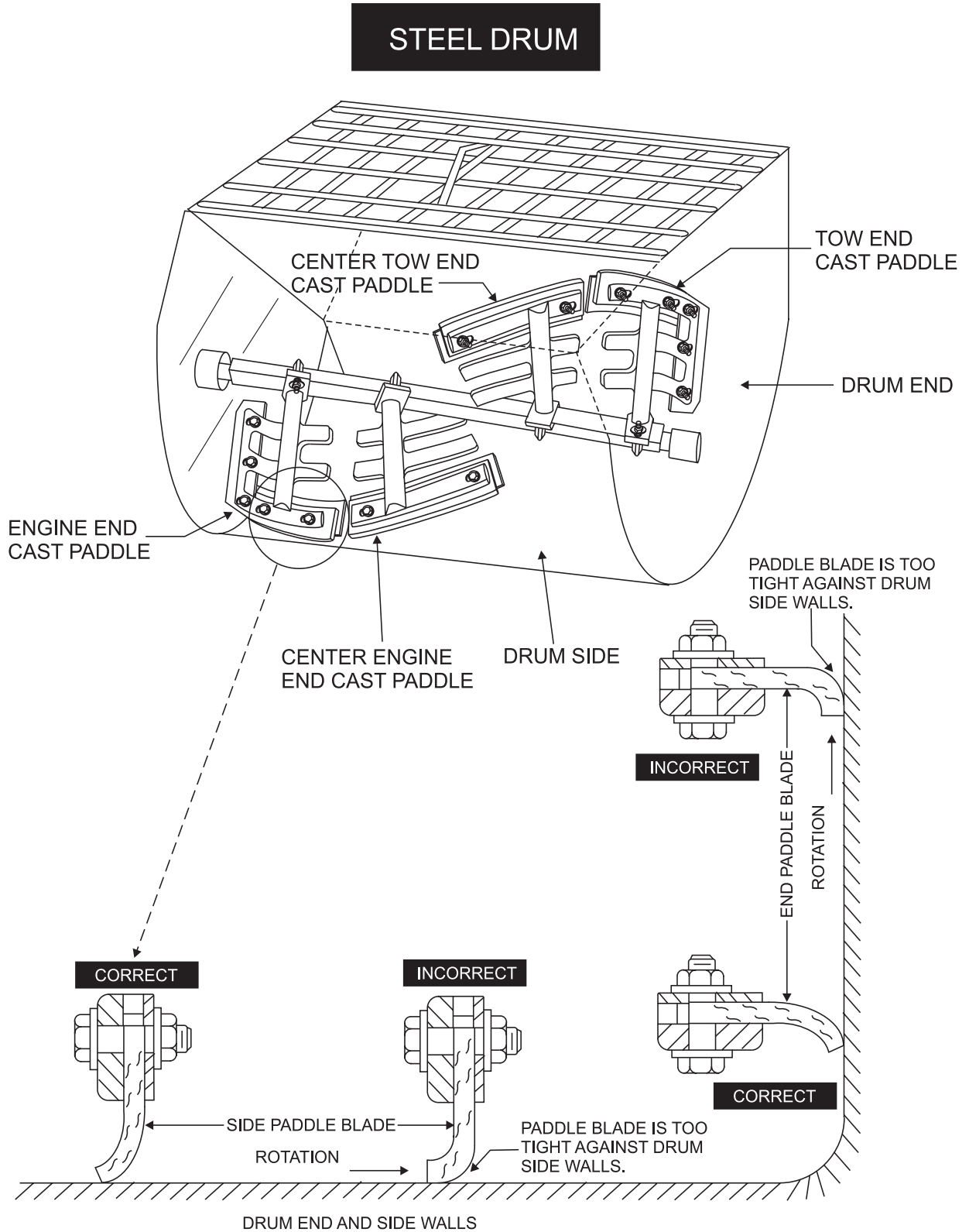


Figure 3. Paddle Blade Adjustment, Steel Drum

# EM-900SDCE MIXER — INSPECTION

See Figures 1 and 2 (Pages 11 and 12) for the location of any control or component referenced in this manual.

## FUEL

1. Lift the fuel cap latch (Figure 1) located on top of the fuel tank, then look inside the tank and determine if the engine fuel is low. If fuel is low, fill with **diesel fuel** (Figure 4).



## CAUTION

Handle fuel safely. Motor fuels are highly **flammable** and can be dangerous if mishandled. **DO NOT** smoke while refueling. **DO NOT** attempt to refuel mixer if the engine is hot or running. **ALWAYS** allow engine to **cool** before refueling.

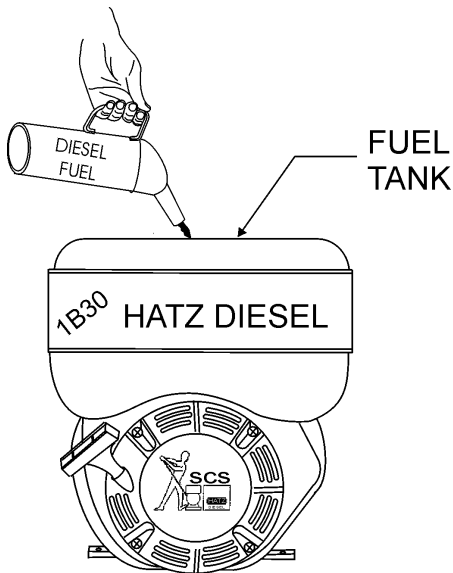


Figure 4. Fuel Tank

## ENGINE OIL

1. Remove the engine oil dipstick from its holder (Figure 5).

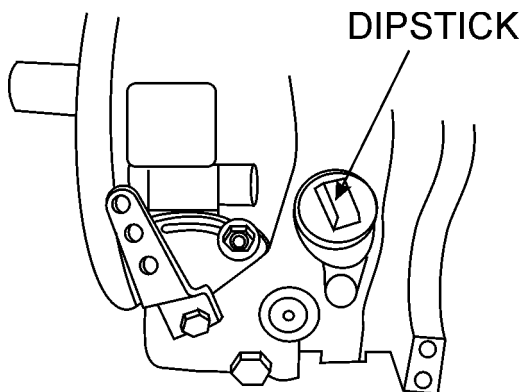


Figure 5. Oil Filler Port/Dipstick

2. Determine if the engine oil is low (Figure 6), add correct amount of engine oil to bring oil level to a normal safe level. See Table 4 for recommended oil type.

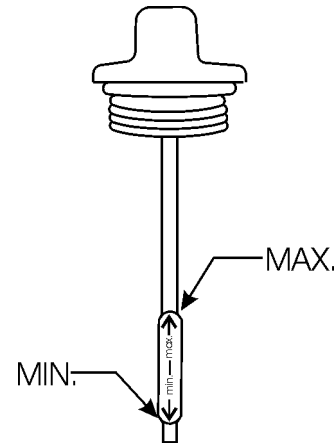


Figure 6. Dipstick

## ZERK GREASE FITTINGS

1. Check the zerk grease fittings at each end of the mixing drum (Figure 7). These grease fittings lubricate the dumping mechanism. If the dumping handle is stiff or hard to move lubricate these fittings.

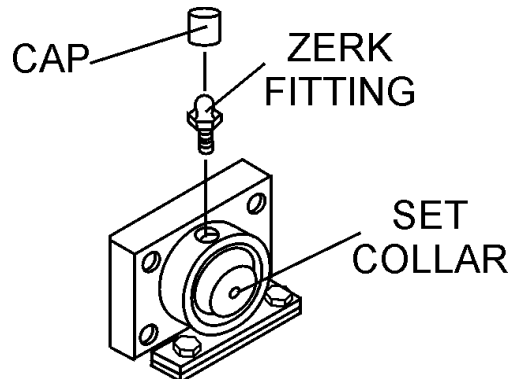


Figure 7. Zerk Fittings (Bearings)



## LUBRICANTS

### CLUTCH OIL

1. Remove the clutch **oil level plug** (Figure 8). If oil begins to seep out as the plug is being removed, then it can be assumed that the clutch oil is at the proper operating level.
2. If oil does not seep out as the oil level plug is being removed, then remove the **clutch oil fill plug** and fill with SAE 30 engine oil to the proper operating level.

### GEAR REDUCTION OIL (TRANSMISSION)

1. Remove the **transmission oil level plug** (Figure 8). If oil begins to seep out as the plug is being removed, then it can be assumed that the transmission oil is at the proper operating level.
2. If oil does not seep out as the oil level plug is being removed, then remove the **transmission oil fill plug** and fill with SAE 90 transmission oil to the proper operating level.

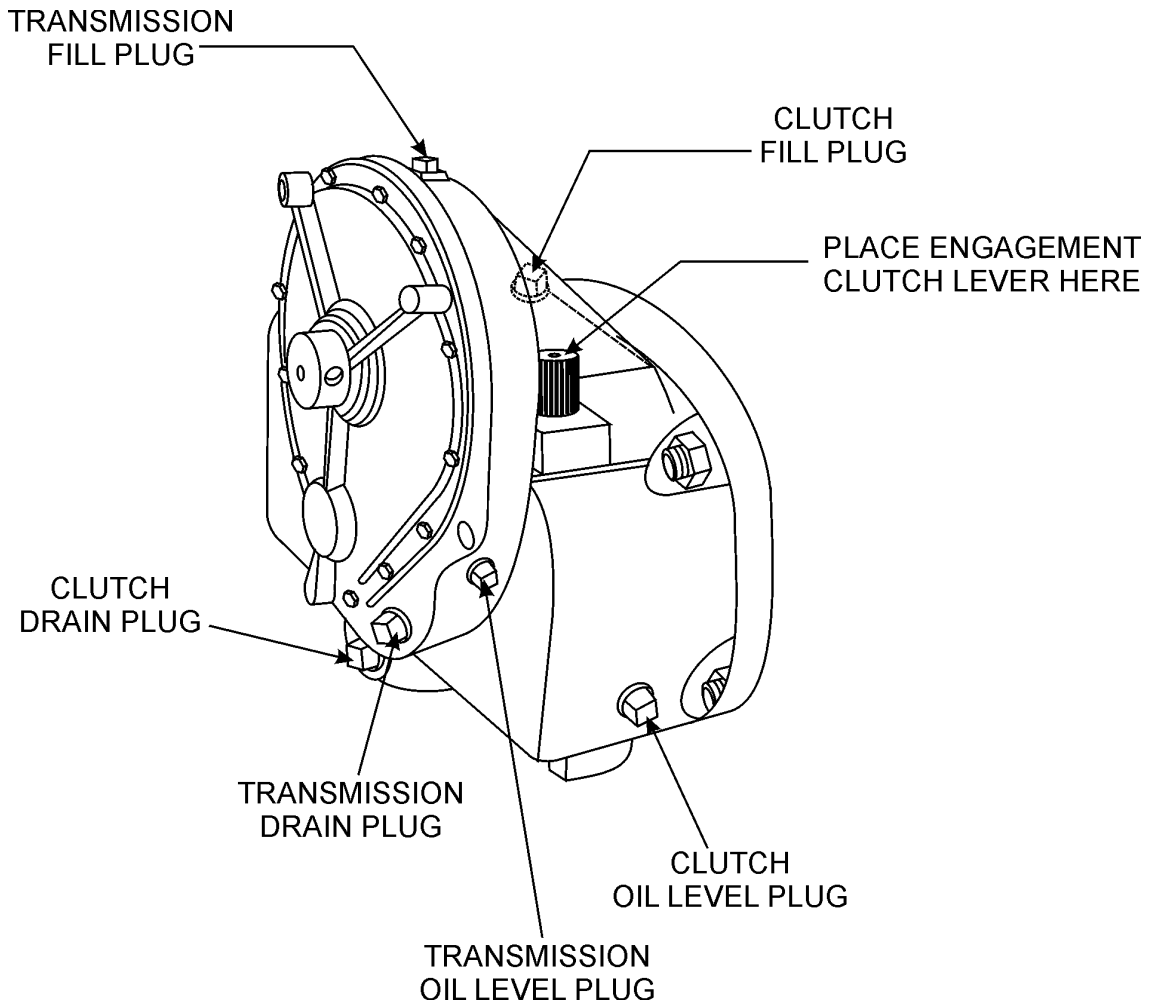


Figure 8. Transmission/Clutch Lubrication

# EM -900SDCE MIXER — INITIAL START-UP

This section is intended to assist the operator with the initial start-up of the EM-900SDCE mixer. It is extremely important that this section be read carefully before attempting to use the mixer in the field.

**DO NOT** use your mixer until this section is thoroughly understood.

## CAUTION

Failure to understand the operation of the EM-900SDCE mixer could result in severe damage to the mixer or personal injury.

### STARTING THE ENGINE

The following steps outline the procedure for starting the engine.

1. Make sure the clutch engagement lever is in the dis-engage position (lever is pointing towards the **engine end**).
2. **PUSH** the "RED" button (Figure 9) on the throttle control and pull the round black knob about halfway out. Make sure that the throttle lock knob has been dis-engaged.

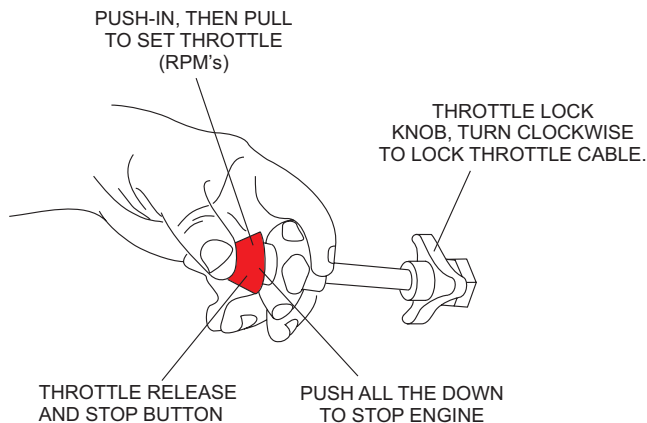


Figure 9. Throttle Control Knob

6. **Pull** the **starter grip** (Figure 10) lightly until you feel resistance, then pull briskly. Return the starter grip gently.

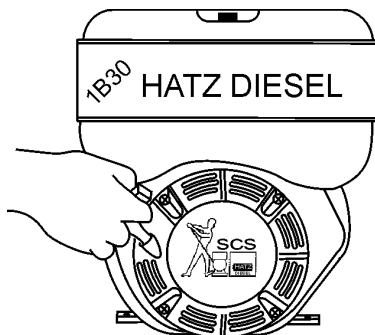


Figure 10. Starter Grip

7. **Push** the clutch engagement lever forward (Figure 11), toward the **tow end** of the mixer. When engine starts adjust throttle lever so that paddle shaft inside mixer rotates between 30 - 40 RPM's. The number of RPM's will vary depending on engine type and load.

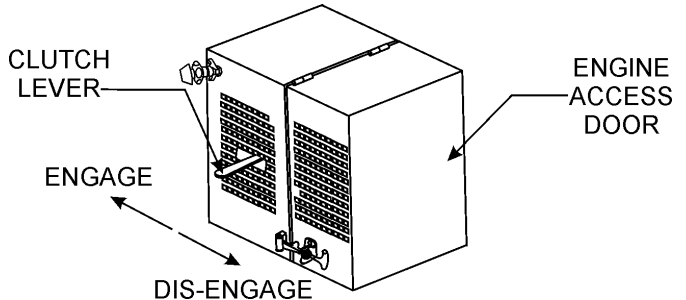
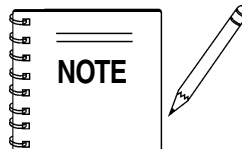


Figure 11. Clutch Engagement Lever

### MIXING

1. The paddle shaft inside the drum should be rotating at this time.
2. Lift the mixing bag compound onto the steel grate over the bag cutter and let the contents fall into the drum.
3. Add water, and mix compound to desired consistency,



Be sure to stand clear of the **dump handle** when the mixer is operational. Any binding of material between the mixer blades and the drum will cause the drum handle to move to the discharge position, thus causing bodily harm.

### STOPPING THE ENGINE

1. Place the clutch engagement lever in the dis-engage position (lever is pointing towards the **engine end**).
2. **PUSH** the "RED" throttle button halfway in (idle speed). Allow the engine to cool for 3-5 minutes.
3. **PUSH** the "RED" throttle button all the way in, this will stop the engine.

# EM-900SDCE MIXER — MAINTENANCE

## SHAFT SEALS

### CAUTION

#### IMPORTANT -DRUM HEAD SEAL CARE

Grease seals every 40 hours of operation using any grade #1 lithium base grease. Apply grease until visible inside of mixing tub (over grease). This will purge seal system of contamination.

The clutch reduction assembly has two separate compartments. Each of which must be filled with its proper lubricant and checked at regular intervals.

The **clutch compartment** should be filled with a good grade of number 30 SAE engine oil which can be poured through the filler hole located just above the clutch inspection door on the opposite side of the transmission. Fill the clutch compartment with 30 SAE engine oil until it overflows the oil level plug located on the shifter side of the clutch compartment. Check this oil level every two or three months and add oil as required. Drain and refill once a year.

The **reduction gear, upper compartment** should be filled with number 90 SAE oil, as used in automobile transmissions. The filler plug is at the top of the reduction gear case and the oil level plug is on the same side of the case as the clutch lever. Fill the reduction gear compartment with 90 SAE transmission oil until it overflows the oil level plug. Check this oil level every two or three months and add oil as required. Drain and refill once a year.

## PADDLE SHAFT BEARINGS

The paddle shafts in the Multiquip EM900SDCE mixers rotate in sealed ball bearings, which require no additional lubrication as they are packed and sealed at the factory.

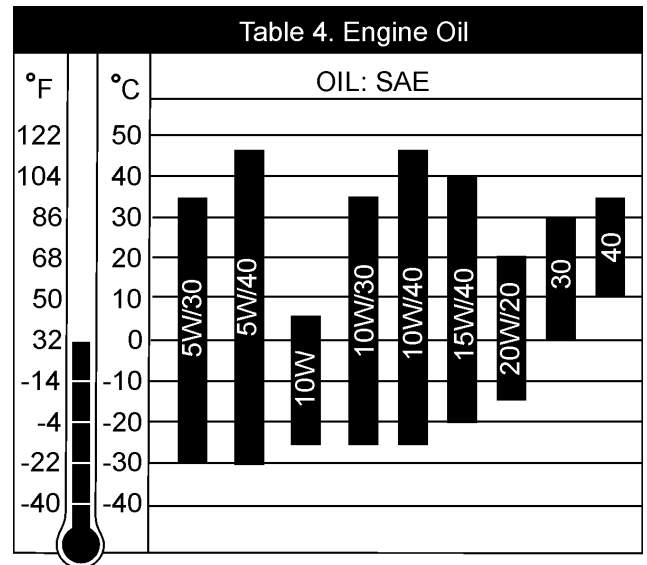
There is, on each end of the mixing drum, a zerk grease fitting (pivot point). Grease these fittings once a week as they lubricate the dumping mechanism of the mixing drum.

### CAUTION

**Failure** to lubricate the zerk grease fittings once a week will cause the dumping mechanism to stiffen, making the mixer hard to dump.

## ENGINE OIL

1. If engine oil is low, fill engine crankcase with lubricating oil through filler hole (Figure 1), but **DO NOT** overfill.
2. The oil listed in Table 4 is recommended to ensure better engine performance. Use class CD or higher grade motor oil.



## AIR CLEANER (DRY TYPE)

1. Change the air cleaner every 500 hours. See Figure 1 for location of air cleaner.

## FUEL FILTER/FUEL TANK

1. Change the fuel filter every 500 hours. Fuel filter is located inside fuel tank.
2. Siphon water out of fuel tank once a year.

## CLEANING

**ALWAYS** make sure engine is **OFF** before cleaning the inside of the drum. **NEVER** put hands, fingers or arms inside mixing drum when engine is **ON**.

**NEVER** pour or spray water over engine.

For consistent performance, long life and high quality mixing, thoroughly clean the mixer inside and out at the end of each day's operation. To prevent lumps of dried mortar from forming and contamination of future batches, **DO NOT** allow a buildup of materials to form on the blades or anywhere inside the drum.

## Clutch Adjustment Mechanical 9 CF Mixer

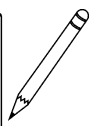
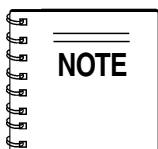
If the rotating mixing paddles appear to be losing rotational speed, it may be necessary to adjust the clutch. For optimum performance Multiquip recommends 47.45-74.57 N-m (35-55 ft-lbs). applied pressure to the hand clutch lever. After the first initial operating hours (8) check the clutch for proper ensasment pressure.

### Clutch Adjustment Procedure

#### **CAUTION**

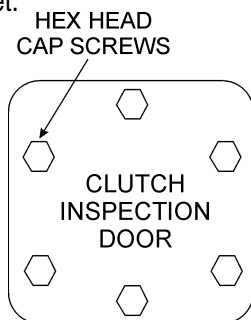
**ALWAYS** stop the engine before attempting this procedure.

1. To gain access to the " Gear Reduction Compartment" remove the four 14 mm (9/16-inch) hex head bolts that secure the hood to the engine and remove engine hood.
2. Drain the clutch compartment oil (Figure 8) by removing the magnetic 9 mm (3/8-inch) plug located at the bottom of the Gear Reduction Assembly.



The Gear Reduction Compartment consist of two compartments, a lower and upper. The **lower** compartment houses the clutch, the **upper** compartment contains the actual gear reduction. Remember each compartment requires a different type of lubricating oil.

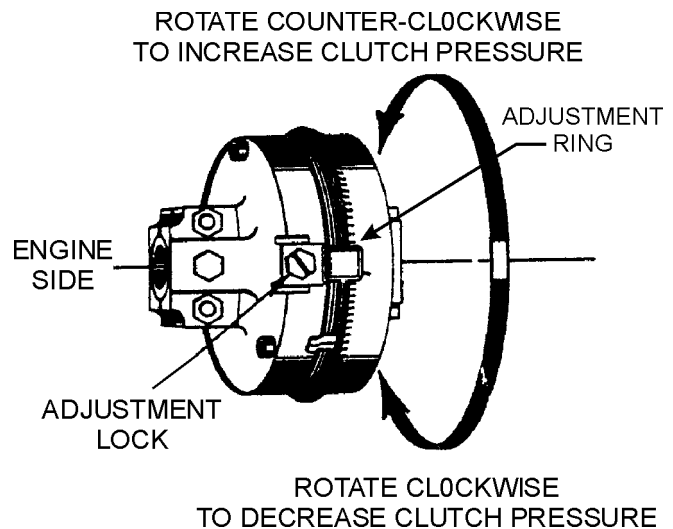
3. To gain access to the "**clutch Inspection door**" remove the six 12 mm (1/2-inch) cap screws (Figure 12) and lock washers that secure the clutch inspection door. Remove door and gasket.



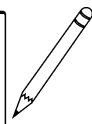
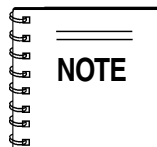
**Figure 12. Clutch Inspection Door**

4. Check that the clutch is disengaged by pulling the shifter lever towards the engine end of the mixer.
5. Refer to Figure 13 for steps 5A through 5F:

- A. Rotate the clutch using the recoil starter until the **adjustment lock** (Figure 13) P/N EM934040 is visible. Using a flat blade screwdriver loosen the adjustment bolt just enough to release the adjustment lock.
- B. Using a punch, rotate the **adjusting ring** P/N EM 934045 one notch at a time in the counter-clockwise direction until a firm 47.45-74.57 N-m (35- 55 lbs.) pressure is felt when engaging the clutch lever (the lever should snap into the engaged position).

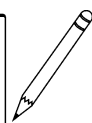
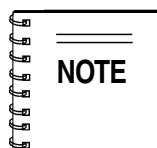


**Figure 13. Clutch Adjustment Lock Location**



If the clutch cannot be adjusted, it may be necessary to inspect or replace the clutch.

- C. When the clutch has been satisfactorily adjusted reinstall the **adjustment lock** P/N EM 934040 and tighten lock bolt.
- D. Reinstall the **clutch Inspection door** using the six 12 mm (1/2-inch) cap screws and lock washers, and also check that the gasket is not worn or broken.
- E. Remove the 9 mm (3/8-inch) square head pipe plug located on the lower clutch compartment. Refill the clutch compartment with 2.12 liters (2-1/4 quarts) of SAE 30 motor oil to the level of the plug. When done reinstall plug.
- F. Start engine, check for proper clutch engagement and inspect for any oil leaks.



Any questions regarding the above procedure please contact the Multiquip Service Department.

# EM-900SDCE MIXER — TROUBLESHOOTING (ENGINE)

Practically all breakdowns can be prevented by proper handling and maintenance inspections, but in the event of a breakdown, please take a remedial action following the

diagnosis based on the Engine Troubleshooting (Table 5) information shown below and on the proceeding page. If the problem cannot be remedied, please leave the unit just as it is and consult our company's business office or service plant.

**TABLE 5. ENGINE TROUBLESHOOTING**

SYMPTON	POSSIBLE PROBLEM	SOLUTION
Engine will not start or start is delayed, although engine can be turned over.	Speed control lever is in "STOP" position?	Set speed control lever to "START" position.
	No fuel reaching injection pump?	Add fuel. Check entire fuel system.
	Defective fuel pump?	Replace fuel pump.
	Fuel filter clogged?	Replace fuel filter and clean tank.
	Faulty fuel supply line?	Replace or repair fuel line.
	Compression too low?	Check piston, cylinder and valves. Adjust or repair per engine repair manual.
	Fuel injector not working correctly?	Repair or replace injector in accordance with engine repair manual.
	Oil pressure too low?	Check engine oil pressure.
	Low starting temperature limit exceeded	Comply with cold starting instructions and proper oil viscosity.
At low temperatures engine will not start.	Fuel separates has inadequate resistance to low temperatures?	Check whether clear (not turbid) fuel emerges from the fuel line (detach from injection pump). If the fuel is turbid or separated, warm up the engine or drain the complete fuel supply system. Refuel with winter grade diesel fuel.
	Engine oil too thick?	Refill engine crankcase with correct type of oil for winter environment.
Engine fires but stops soon as starter is switched off.	Throttle lever in STOP position?	Reposition throttle lever to RUN position.
	Fuel filter blocked?	Replace fuel filter.
	Fuel supply blocked?	Check the entire fuel system.
Engine stops by itself during normal operation.	Fuel tank empty?	Add fuel.
	Fuel filter blocked?	Replace fuel filter.

# EM-900SDCE MIXER — TROUBLESHOOTING (ENGINE/MIXER)

**TABLE 5. ENGINE TROUBLESHOOTING (CONTINUED)**

SYMPTON	POSSIBLE PROBLEM	SOLUTION
Low engine power, output and speed.	Fuel tank empty?	Replace fuel filter.
	Fuel filter clogged?	Replace fuel filter.
	Fuel tank venting is inadequate?	Ensure that tank is adequately vented.
	Speed control lever does not remain in selected position?	See engine manual for corrective action.
	Engine oil level too full?	Correct engine oil level?
Low engine power output and low speed, black exhaust smoke.	Air filter blocked?	Clean or replace air filter.
	Incorrect valve clearances?	Adjust valves per engine specification.
	Malfunction at injector?	See engine manual.

Practically all breakdowns can be prevented by proper handling and maintenance inspections, but in the event of a breakdown, please take a remedial action following the diagnosis based on the Mixer Troubleshooting (Table 6) information shown below. If the problem cannot be remedied, please leave the unit just as it is and consult our company's business office or service plant.

**TABLE 6. MIXER TROUBLESHOOTING**

SYMPTOM	POSSIBLE PROBLEM	SOLUTION
Blades will not rotate.	Broken connector pin?	Replace connector pin. Use P/N 963157 when ordering.
	Defective or mis-adjusted clutch?	Adjust or replace clutch.
Material leaking from drum ends.	Worn or defective paddle shaft seals?	Adjust or replace seals.
Drum difficult to discharge (tilt)	Malfunction in air-cleaner system, air filter clogged?	Clean or replace air filter.
	Defective or worn drum support brackets?	Apply grease to bracket or replace.
	Blades adjusted too tight.	Adjust blades until they almost touch side walls of drum.



# EXPLANATION OF CODE IN REMARKS COLUMN

How to read the marks and remarks used in this parts book.

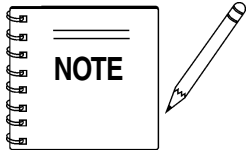
## Section 1: Items Found In the “Remarks” Column

**Serial Numbers-**Where indicated, this indicates a serial number range (inclusive) where a particular part is used.

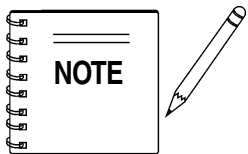
**Model Number-**Where indicated, this shows that the corresponding part is utilized only with this specific model number or model number variant.

## Section 2: Items Found In the “Items Number” Column

All parts with same symbol in the number column, \*, #, +, %, or >, belong to the same assembly or kit.



If more than one of the same reference number is listed, the last one listed indicates newest (or latest) part available.



The contents of this parts catalog are subject to change without notice.



# EM-900SDCE MIXER — SUGGESTED SPARE PARTS

## EM-900SDCE 1 TO 3 UNITS

Qty.	P/N	Description
6	491010	RUBBER LATCH ASSY.
1	EM200293	PADDLE ARM TOW SIDE
1	EM200294	PADDLE ARM CENTER TOW SIDE
1	EM200295	PADDLE ARM CENTER ENGINE SIDE
1	EM200296	PADDLE ARM ENGINE SIDE
3	EM200863	RUBBER BLADE KIT (STEEL DRUM)
2	EM200297	U-BOLT
2	EM200268	U-BOLT
2	EM902153	BEARING, PADDLE SHAFT
3	EM963157	CONNECTOR BOLT
1	EM934041	CLUTCH, DRIVEN MEMBER
6	EM200301	PACKING RING
1	3249	CAP, DUST
2	20561-001	BEARING SEALED
4	EM200285	PACKING GLAND
4	507844	SPRING
4	EM200286	CARRIAGEBOLT SPECIAL
2	EM200287	ADJUSTMENT BOLT

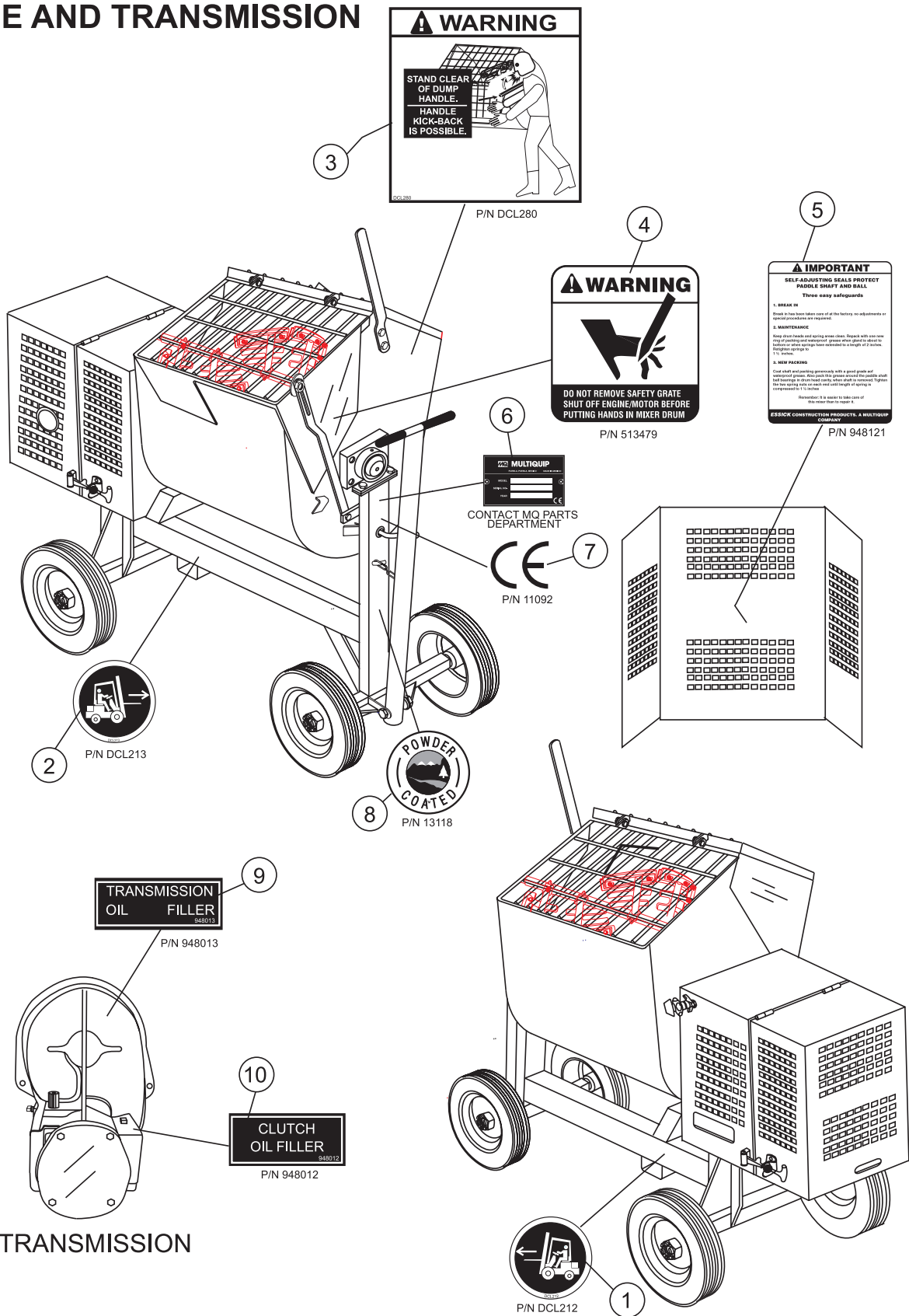
## EM-900SDCE 5 TO 10 UNITS

Qty.	P/N	Description
4	491010	RUBBER LATCH ASSY.
2	EM200293	PADDLE ARM TOW SIDE
2	EM200294	PADDLE ARM CENTER TOW SIDE
2	EM200295	PADDLE ARM CENTER ENGINE SIDE
2	EM200296	PADDLE ARM ENGINE SIDE
6	EM200863	RUBBER BLADE KIT (STEEL DRUM)
4	EM200297	U-BOLT
4	EM200268	U-BOLT
4	EM902153	BEARING, PADDLE SHAFT
5	EM963157	CONNECTOR BOLT
1	EM934041	CLUTCH, DRIVEN MEMBER
24	EM200301	PACKING RING
2	3249	CAP, DUST
4	20561-001	BEARING SEALED
8	EM200285	PACKING GLAND
8	507844	SPRING
8	EM200286	CARRIAGEBOLT SPECIAL
4	EM200287	ADJUSTMENT BOLT

# EM-900SDCE MIXER — NAME PLATE AND DECALS

## NAME PLATE AND DECALS

### FRAME AND TRANSMISSION



### TRANSMISSION

# EM-900SDCE — NAME PLATE AND DECALS

## NAME PLATE AND DECALS

<u>NO</u>	<u>PART NO</u>	<u>PART NAME</u>	<u>QTY.</u>	<u>REMARKS</u>
1	DCL212	DECAL: FORKLIFT (LEFT)	1	
2	DCL213	DECAL: FORKLIFT (RIGHT)	1	
3	DCL280	DECAL: WARNING, STAND CLEAR OF DUMP HANDLE	1	
4	513479	DECAL: WARNING, DO NOT REMOVE SAFETY GRATE	1	
5	948121	DECAL: IMPORTANT, SELF ADJUSTING SEALS	1	
6		PLATE : SERIAL NO. ....	1	CONTACT MQ PARTS DEPT. W/MODEL & S/N
7	11092	DECAL: CE	1	
8	13118	DECAL: POWDER COATED	1	
9	948013	DECAL: TRANSMISSION OIL FILLER	1	
10	948012	DECAL: CLUTCH OIL FILLER	1	

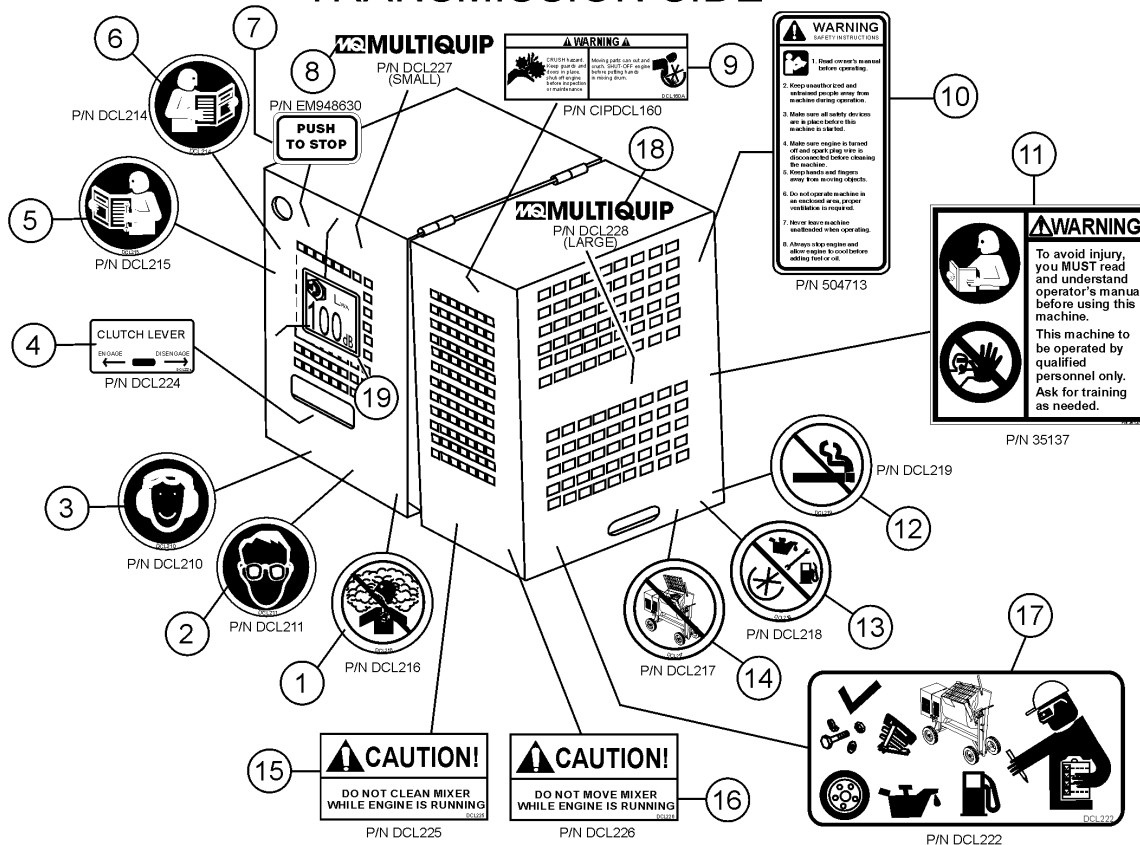
SEE DECAL ILLUSTRATIONS ON PAGES 6 AND 7.

# EM-900SDCE — NAME PLATE AND DECALS

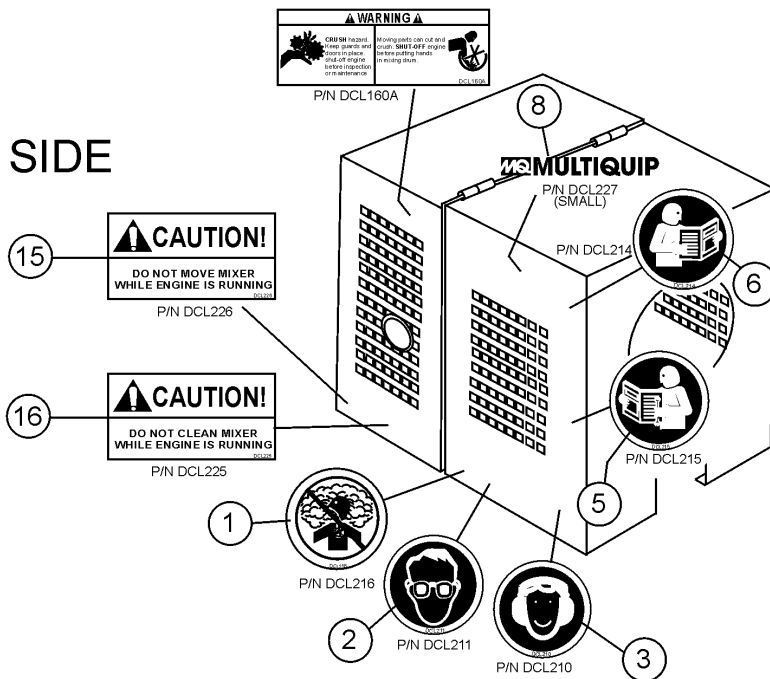
## NAME PLATE AND DECALS

### ENGINE ENCLOSURE

#### TRANSMISSION SIDE



#### ENGINE SIDE



## EM-900SDCE — NAME PLATE AND DECALS

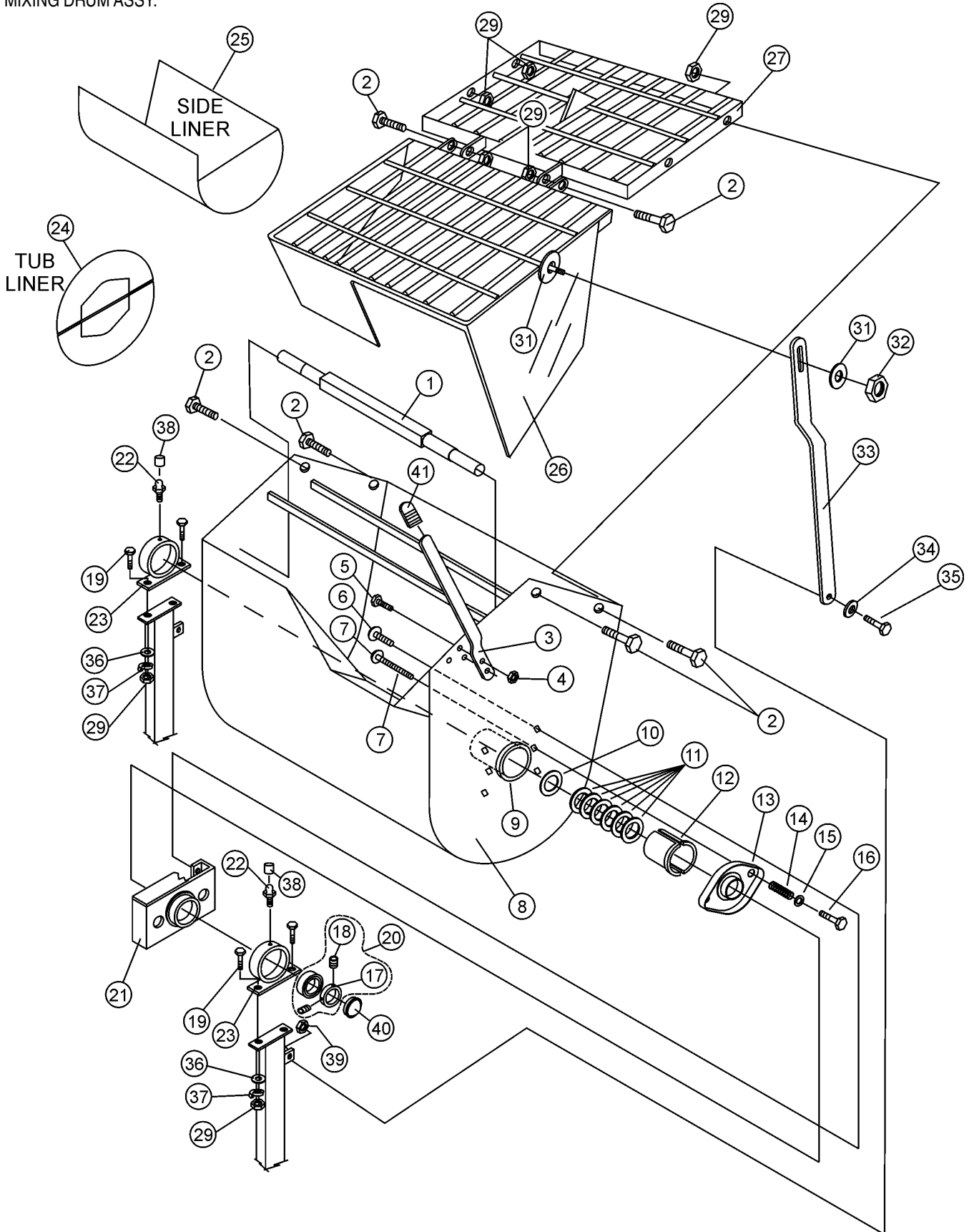
### NAME PLATE AND DECALS

<u>NO</u>	<u>PART NO</u>	<u>PART NAME</u>	<u>QTY.</u>	<u>REMARKS</u>
1	DCL216	DECAL: DANGEROUS FUMES	1	
2	DCL211	DECAL: EYE PROTECTION	1	
3	DCL210	DECAL: HEARING PROTECTION	1	
4	DCL224	DECAL: CLUTCH LEVER	1	
5	DCL215	DECAL: READ SERVICE MANUAL	1	
6	DCL214	DECAL: READ OPERATION MANUAL	1	
7	EM948630	DECAL: PUSH TO STOP	1	
8	DCL227	DECAL: MULTIQUIP (SMALL)	2	
9	CIPDCL160	DECAL: WARNING CRUSH HAZD.	2	
10	504713	DECAL: WARNING, READ OWNER'S MANUAL	1	
11	35137	DECAL: WARNING, AVOID INJURY (READ MANUAL)	1	
12	DCL219	DECAL: NO SMOKING	1	
13	DCL218	DECAL: NO MAINT. WHEN RUNNING	1	
14	DCL217	DECAL: KEEP GRATE CLOSED	1	
15	DCL225	DECAL: DO NOT CLEAN MIXER	1	
16	DCL226	DECAL: DO NOT MOVE MIXER	1	
17	DCL222	DECAL: INSPECTION	1	
18	DCL228	DECAL: MULTIQUIP (LARGE)	1	
19	DCL330	DECAL: NOISE LEVEL	1	

SEE DECAL ILLUSTRATIONS ON PAGES 6 AND 7.

# EM-900SDCE MIXER — MIXING DRUM ASSEMBLY

MIXING DRUM ASSY.



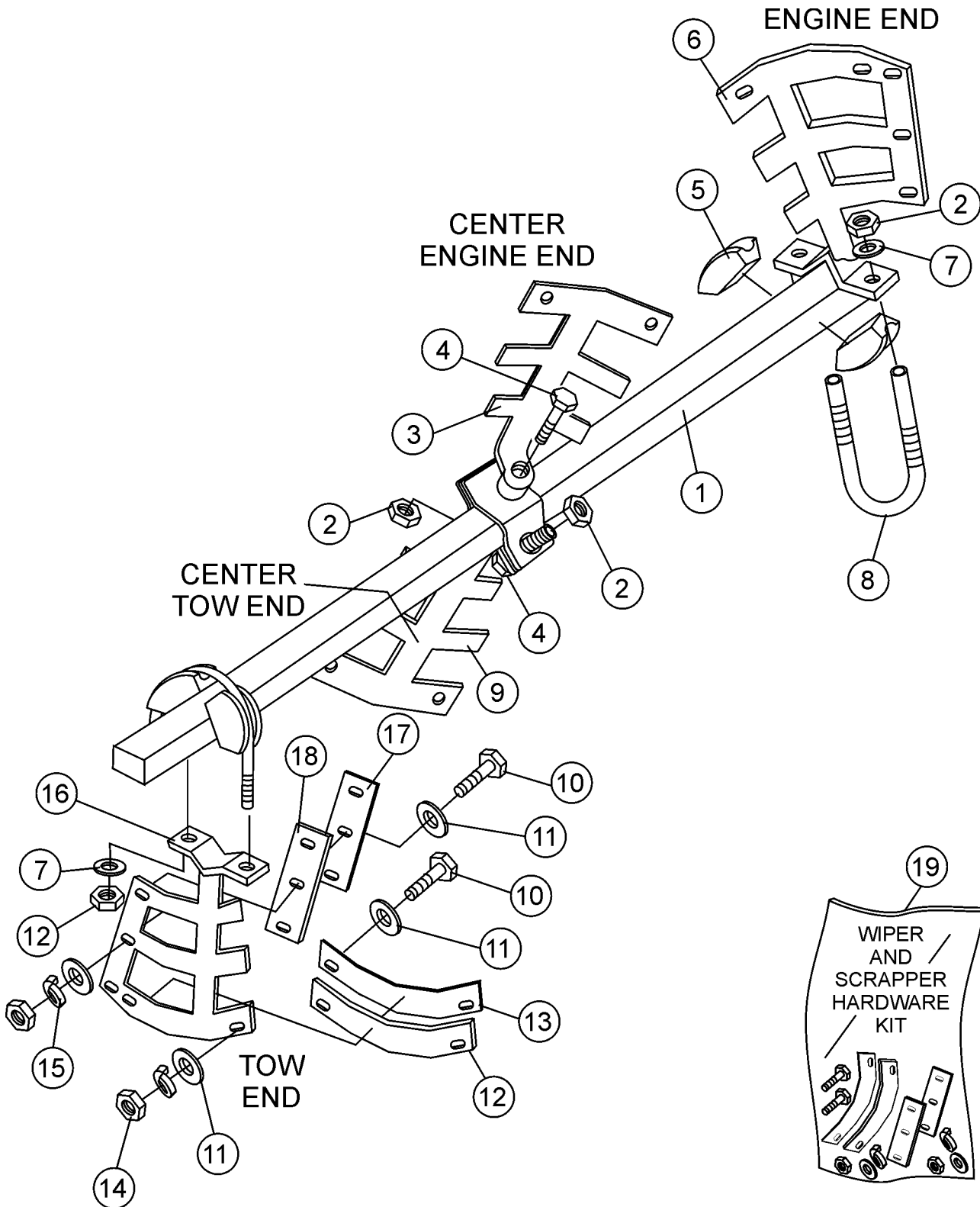
# EM-900SDCE MIXER — MIXING DRUM ASSEMBLY

## MIXING DRUM ASSY.

<u>NO</u>	<u>PART NO</u>	<u>PART NAME</u>	<u>QTY.</u>	<u>REMARKS</u>
1	512990	PADDLE SHAFT	1	
2	EM963610	SCREW, HHCS 3/8 "NC X 1-1/4" G5 .....	6	REPLACES P/N 492375
3	EM201537	HANDLE, DUMP	1	
4	6109160	NUT, HEX 1/2" .....	2	REPLACES P/N 492556
5	EM963692	BOLT, 1/2" UNC X 1-1/2	2	
6	EM966048	CARRIAGE BOLT 3/8-16 x 1-1/4	8	
7	EM200286	CARRIAGE BOLT SPECIAL	4	
8	512983	DRUM ASSY.	1	
9	EM200237	PACKING BOX WELDMENT	2	
10	EM200303	FOLLOWER RING	2	
11	EM200301	PACKING RING	12	
12	EM200285	PACKING GLAND	4	
13	EM200288	PRESSURE PLATE	2	
14	507844	SPRING	4	
15	492602	WASHER, FLAT 5/8"	4	
16	EM200287	ADJUSTMENT BOLT	4	
17	EM200018	SET COLLAR	2	
18	492470	SET SCREEN	4	
19	EM963057	SCREW, HHCS 3/8" X 1-1/2" .....	2	REPLACES P/N 505196
20	20561-001	BEARING, SEALED	2	
21	EM201648	DRUM HEAD	2	
22	EM916019	GREASE, ZERK FITTING .....	2	REPLACES P/N 491705
23	513153	BRACKET, DRUM	2	
24	512943	END LINER SET	1	
25	512944	SIDE LINER	1	
26	512960	MOVING GRATE	1	
27	512989	FIXED GRATE	1	
29	EM969013	LOCK NUT 3/8" .....	6	REPLACES P/N 492583
31	506109	WASHER	1	
32	EM969023	LOCK NUT .....	1	REPLACES P/N 492586
33	513035	SAFETY BAR	1	
34	492600	WASHER, FLAT 1/2"	1	
35	EM963102	BOLT, G5 .....	1	REPLACES P/N 492393
36	3019092	WASHER, FLAT 3/8 .....	4	REPLACES P/N 492598
37	506488	WASHER, LOCK 3/8	4	
38	491008	CAP, ZERK FITTING	4	
39	492584	LOCK NUT 1/2"	2	
40	3249	CAP, DUST	1	
41	15081	GRIP	1	

# EM-900SDCE MIXER — PADDLE SHAFT ASSEMBLY

## PADDLE SHAFT ASSEMBLY





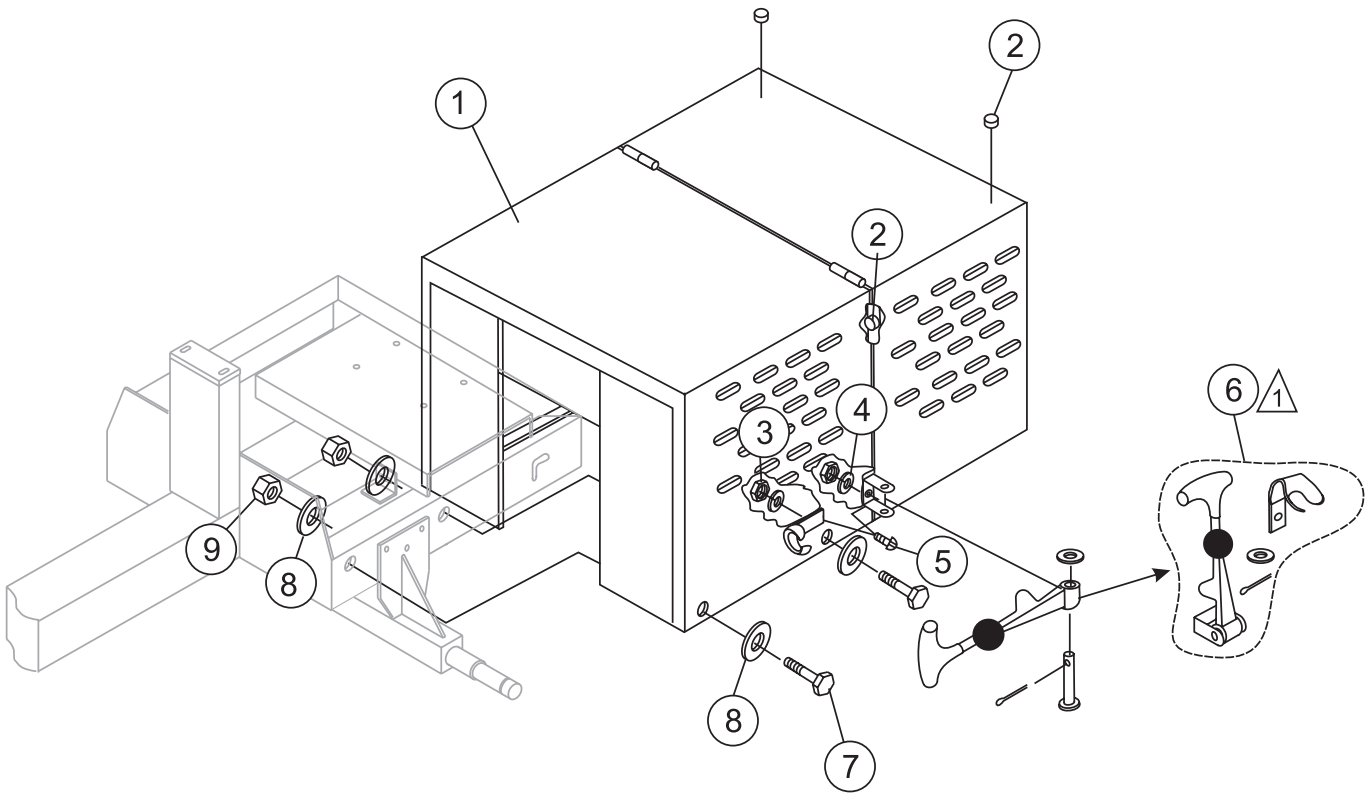
# EM-900SDCE MIXER — PADDLE SHAFT ASSEMBLY ASSEMBLY

## PADDLE SHAFT ASSY.

<u>NO.</u>	<u>PART NO.</u>	<u>PART NAME</u>	<u>QTY.</u>	<u>REMARKS</u>
1	512990	PADDLE SHAFT	1	
2	492584	NUT, LOCK 1/2"	6	
3	EM200295	PADDLE CAST, CENTER ENGINE END	1	
4	510721	BOLT, 1/2 " X 6" G5	2	
5	EM200292	INSERT, PADDLE ARM	4	
6	EM200296	PADDLE CAST, ENGINE END	1	
7	504322	WASHER, FLAT 1/2"	6	
8	EM200297	U-BOLT, END PADDLES	2	
9	EM200294	PADDLE CAST, CENTER TOW END	1	
10*	492367	SCREW, HHC 5/16-18 X 1-3/4 G5	14	
11*	EM923023	WASHER, FLAT 5/16"	28	
12*	EM200212	WIPER, BOTTOM, RUBBER	4	
13*	EM203432	TOP SCRAPPER BLADE	4	
14*	2105164	NUT, HEX 5/16" NC G5	14	
15*	EM923343	WASHER, LOCK 5/15"	14	
16	EM200293	PADDLE CAST, TOW END	1	
17*	EM203433	SIDE SCRAPPER BLADE	2	
18*	EM200213	WIPER, RUBBER SIDE	2	
19	EM200863	KIT, WIPERS, SCRAPERS AND HARDWARE .....	1	INCLUDES ITEMS W/*

# EM-900SDCE MIXER — CABINET ASSY.

## CABINET ASSEMBLY



### NOTES:



COMPLETE LATCH ASSEMBLY  
INCLUDES ITEMS WITHIN DASHED  
LINES. ITEMS CANNOT BE PURCHASED  
SEPARATELY.

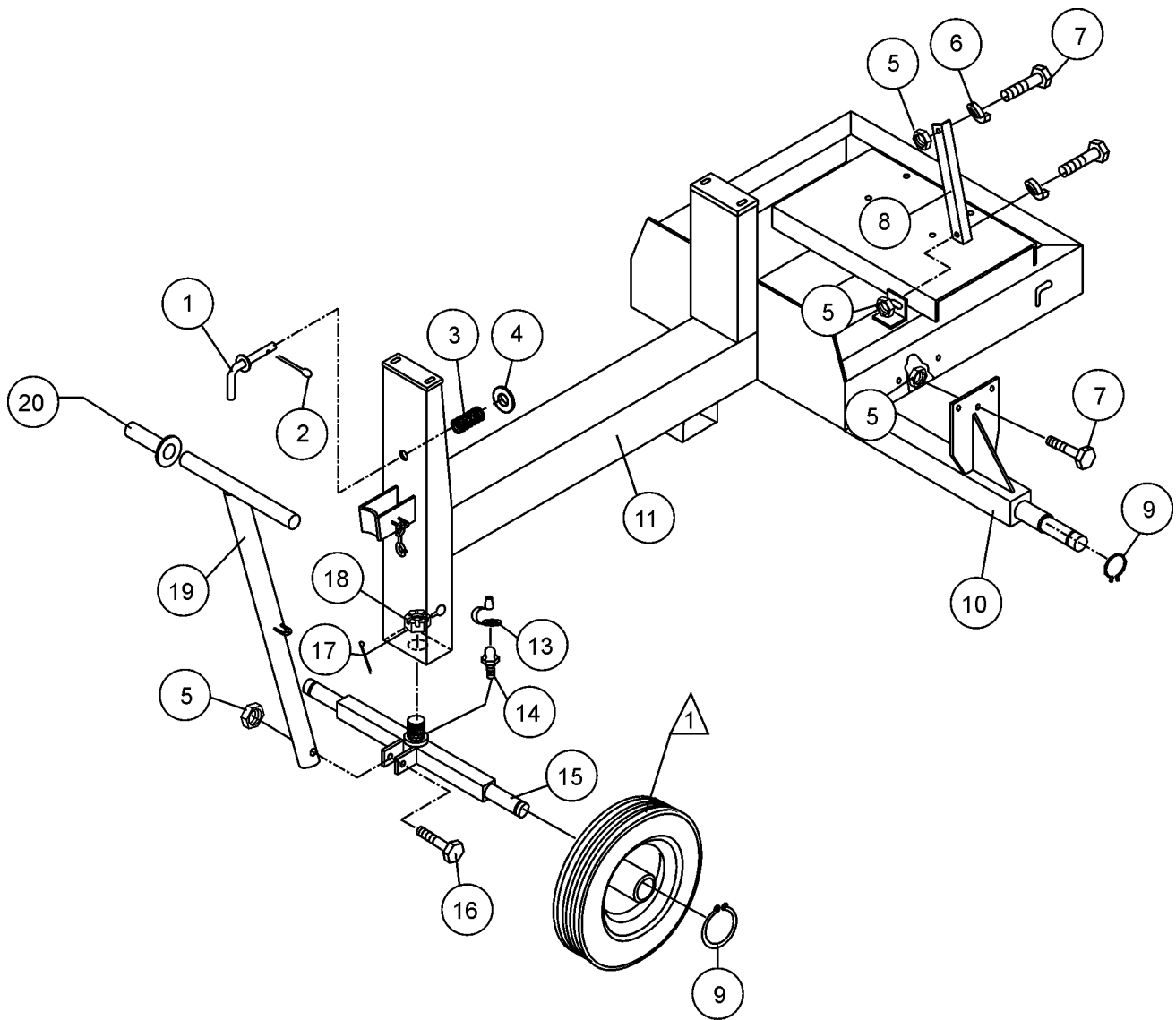
# EM-900SDCE — CABINET ASSY.

## CABINET ASSY.

<u>NO</u>	<u>PART NO</u>	<u>PART NAME</u>	<u>QTY.</u>	<u>REMARKS</u>
1	513053	CABINET, ENGINE W/DECALS .....	1 .....	INCLUDES ITEMS W/*
2	490202	RUBBER PROTECTOR	4	
3	13287	LOCK NUT 8-32 .....	6 .....	REPLACEMENT PART ONLY
4	2203	WASHER, FLAT #10 .....	6 .....	REPLACEMENT PART ONLY
5	1307	SCREW RHMS 8-32 X 1/2" .....	6 .....	REPLACEMENT PART ONLY
6*	491010	LATCH ASSY., COMPLETE	2	
7	492375	BOLT 3/8" NC X 1" G5	4	
8	492598	WASHER, FLAT 3/8"	4	
9	492583	NUT 3/8" NC G5	4	

# EM-900SDCE MIXER — FRAME ASSY.

FRAME ASSY.



NOTES:

▲ TIRES AND WHEEL RIM ARE PROVIDED BY MULTQUIP UK.

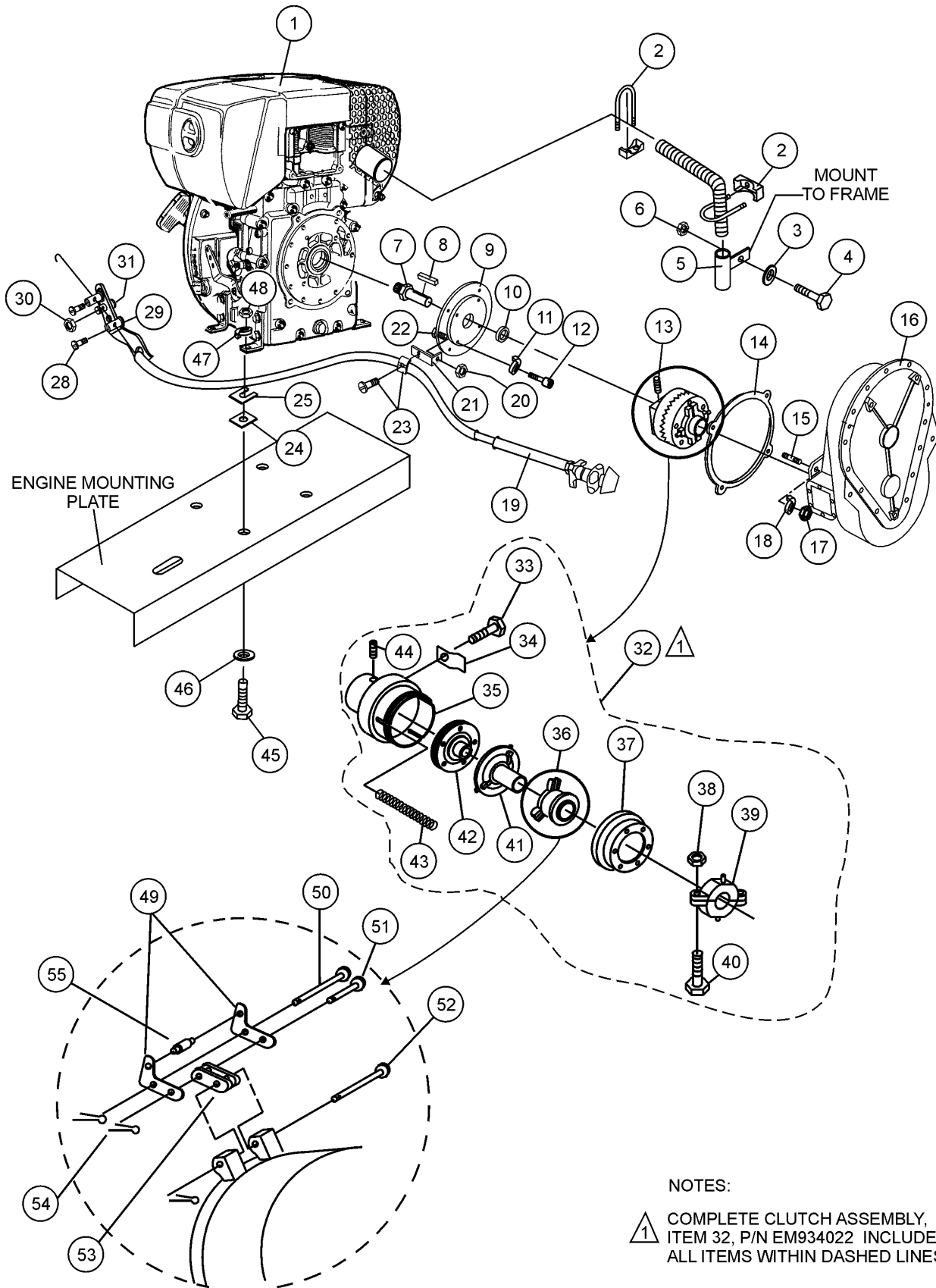
## EM-900SDCE MIXER — FRAME ASSY.

### FRAME ASSY.

<u>NO</u>	<u>PART NO</u>	<u>PART NAME</u>	<u>QTY.</u>	<u>REMARKS</u>
1	514842	DRUM LATCH	1	
2	491692	COTTER PIN 3/16" X 1-1/4"	1	
3	530023	SPRING, COMPRESSION	1	
4	507444	WASHER, FLAT 3/4"	1	
5	492584	NUT, HEX 1/2"	10	
6	504322	WASHER , FLAT 1/2"	4	
7	492394	BOLT, 1/2" NC X 1-1/2" G5	10	
8	513050	SUPPORT BRACKET TRAMSMISSION	1	
9	490957	RETENTION RING 5100-100	4	
10	512937	AXLE, REAR ASSY. (RIGID)	1	
11	513010	FRAME, EM900SD CE	1	
13	491008	GREASE FITTING	1	
14	491700	CAP GREASE FITTING 1/4" NPT	1	
15	512942	AXLE, FRONT ASSY.	1	
16	492400	BOLT, 1/2" NC 3-1/2" G5	1	
17	491692	COTTER PIN 3/16" X 2"	1	
18	492537	CASTLE NUT, 1-1/4" NF	1	
19	513042	HANDLE TOW	1	
20	15081	HAND GRIP	2	

# EM-900SDCE MIXER — HATZ ENGINE ASSY.

HATZ ENGINE ASSY.



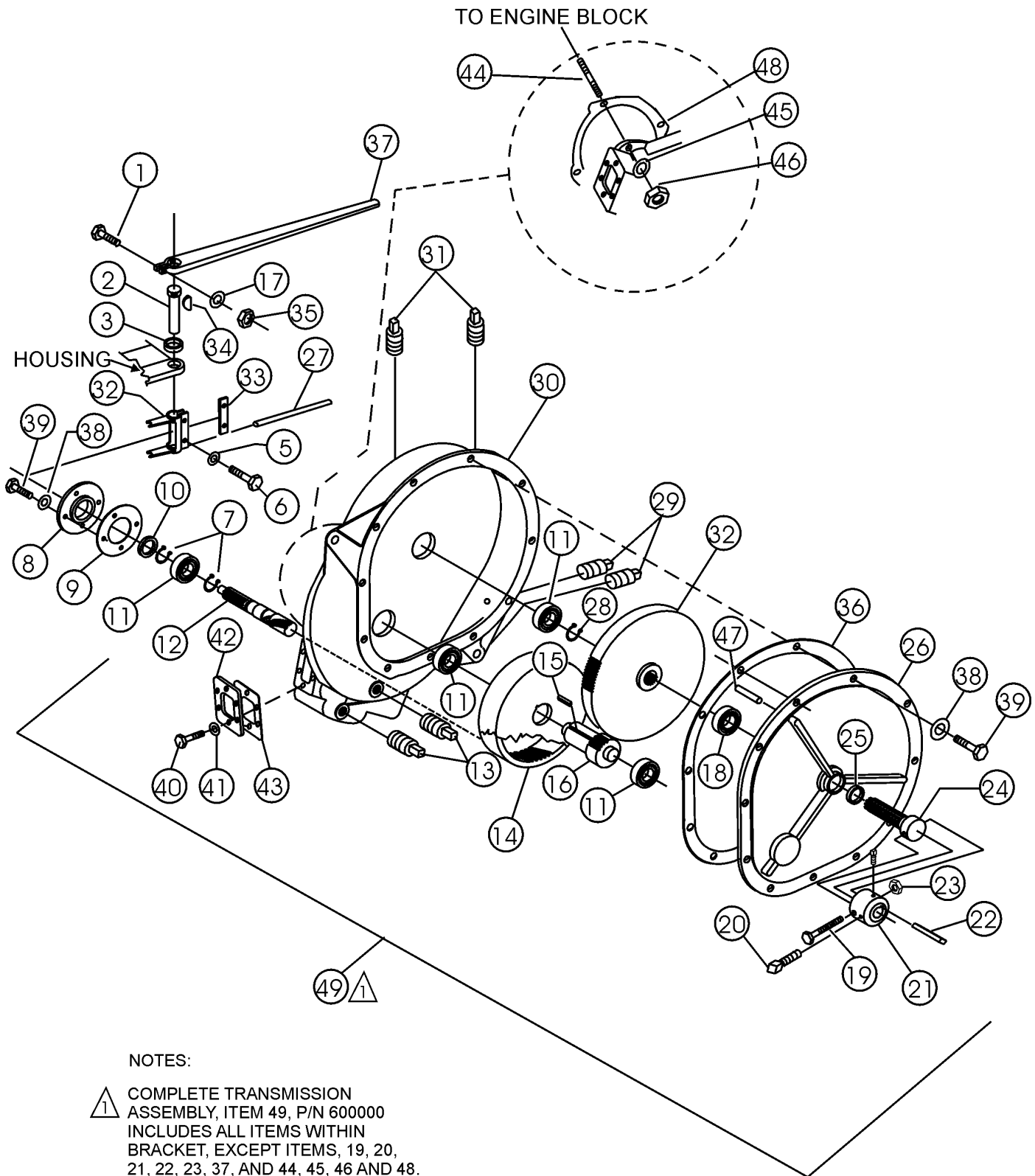
# EM-900SDCE MIXER — HATZ ENGINE ASSY.

## HATZ ENGINE ASSY.

<u>NO</u>	<u>PART NO</u>	<u>PART NAME</u>	<u>QTY.</u>	<u>REMARKS</u>
1	1B30	HATZ DIESEL 6.8 HP	1	
2	506257	U-BOLT	1	
3	504322	WASHER , FLAT 1/2"	1	
4	492394	BOLT, 1/2" NC X 1-1/2" G5	1	
5	513973	EXHAUST MOUNTING TUBE	1	
6	492584	NUT, HEX 1/2"	1	
7	513716	STUB SHAFT	1	
8	502625	KEY, 1/4" X 25 MM	1	
9	513954	ADAPTER PLATE	1	
10	512899	OIL SEAL	1	
11	13379	WASHER, LOCK 3/8"	4	
12	506612	BOLT, M10 X 35 P-1.5G	4	
13	492468	SET SCREW	1	
14	801965	GASKET	1	
15	512223	STUD 7/16" X 2"	4	
16	511121	TRANSMISSION, MECHANICAL	1	
17	492555	NUT, HEX 7/16 G5	4	
18	492625	WASHER, LOCK	4	
19	510229	THROTTLE CABLE	1	
20	492581	NUT, HEX 1/4"	1	
21	512900	BRACKET, THROTTLE CABLE	1	
22	EM963007	CAP SCREW 1-1/4" X 1-1/2" G5 .....	1	REPLACES EM492359
23	TBD	THROTTLE CABLE CLAMP	1	
24	511123	SHIM 0.018"	2	
25	511122	SHIM 0.030"	2	
28	491089	SCREW, CG 8 NC X 1/4" G	2	
29	EM501102	NIPPLE THROTTLE ANCHOR	1	
30	492581	NUT, HEX 1/4"	1	
31	513213	GUIDE, THROTTLE CABLE	1	
32	EM934022	CLUTCH ASSY. ....	1	INCLUDES ITEMS/W#
33#	9503	SLOTTED HHCS 1/4-20 X 1/2"	1	
34#	EM934040	ADJUSTING LOCK	1	
35#	EM934039	CLUTCH HOUSING	1	
36#	EM934043	RELEASE SLEEVE	1	
37	EM492359	ADJUSTMENT RING	2	
38#	EM969009	LOCK NUT	2	
39#	EM934044	RELEASE BEARING ASM	1	
40#	EM963289	BOLT	2	
41#	EM934042	PRESSURE PLATE ASM	1	
42#	EM934041	SPLINED CENTER W/FACING	1	
43#	EM918009	SPRING	3	
44#	EM961045	SET SCREW, 5/16-18 X 1/2"NYLOC	1	
45	492365	BOLT, 5/16" NC X 1-1/4" G5	4	
46	505679	WASHER, FLAT 5/16	4	
47	492623	WASHER, LOCK	4	
48	492553	NUT, HEX 5/16" G5	4	
49#	EM959012	LEVER	6	
50#	EM925016	LONG LINK PIN	3	
51#	EM925018	SHORT LINK PIN	3	
52#	EM925013	LEVER PIN	3	
53#	EM934053	CONNECTING LINK	6	
54#	5117	COTTER PIN	9	
55#	EM934054	ROLLER	3	

# EM-900SDCE — TRANSMISSION ASSY.

TRANSMISSION ASSY.





# EM-900SDCE — TRANSMISSION ASSY.

## TRANSMISSION ASSY.

<u>NO</u>	<u>PART NO</u>	<u>PART NAME</u>	<u>QTY.</u>	<u>REMARKS</u>
1#	2200	SCREW, HHCS 3/8-24 X 2"	1	
2#	EM600029	SHIFTER SHAFT	1	
3#	EM914005	SEAL	1	
4#	EM600028	CLUTCH YOKE	1	
5#	0181 B	LOCK WASHER 1/4"	2	
6#	0730	SCREW, HHCS 1/4-20 X 1"	2	
7#	EM926029	SNAP RING	2	
8#	EM600023	BEARING RETAINER	1	
9#	EM600022	BEARING RETAINER GASKET	1	
10#	914209	SEAL	1	
11#	EM902091	BALL BEARING	4	
12#	EM600016	INPUT PINION SHAFT	1	
13#	EM911329	SQ HEAD MAG. PINE PLUG 3/8"	2	
14#	EM600020	INTERNAL GEAR	1	
15#	EM010062	SQ KEY 3/8 X 1-3/8"	1	
16#	EM600131	OUTPUT DRIVE PINION	1	
17#	10136	FLAT WASHER 3/8"	1	
18#	EM902161	BALL BEARING	1	
19	507658	SCREW, HHCS 5/8 X 4-1/2" G5	1	
20	EM961019	SET SCREW, SQHSS 3/8-16 X 1-1/4" CUP	2	REPLACES P/N 492484
21	512991	PADDLE SHAFT COUPLER	1	
22	EM010022	SQ KEY 3/8 X 3/8 X 1-3/4'	1	
23	EM969023	LOCK NUT 3/8" 1-1/4" .....	1	REPLACES P/N 492586
24#	600015	OUTPUT SHAFT	1	
25#	914207	OIL SEAL	1	
26#	600014	TRANSMISSION COVER	1	
27#	1729	ROLL PIN	1	
28#	EM926036	SNAP RING	1	
29#	EM911064	SQ HEAD PINE PLUG 1/2 NPT	2	
30#	EM600012	MAIN TRANSMISSION HOUSING	1	
31#	EM911356	BREATHER VENT PIPE PLUG 1/2"	2	
32#	EM600133	OUTPUT SHAFT GEAR	1	
33#	EM600024	LOCK PLATE	1	
34#	EM927048	WOODRUFF KEY #A	1	
35#	10133	LOCK NUT 3/8-16	1	
36#	EM600021	TRANSMISSION COVER GASKET	1	
37	EM600018	SHIFTER LEVER	1	
38#	0161 C	LOCK WASHER 3/8"	17	
39#	0202	SCREW, HHCS 5/8-16 X 1"	17	
40#	4196	SCREW, HHCS 3/8-16 X 3/4"	6	
41#	1875	INTER. SHKP WASHER 3/8"	6	
42#	EM931233	SHIFTER COVER	1	
43#	EM600026	SHIFTER COVER GASKET	1	
44	EM300999	STUD 7/16-14 X 2-1/16"	4	
45	2955	LOCK WASHER 7/16"	4	
46	EM968010	HEX NUT 7/16-14	4	
47	EM925109	DOWEL PIN	3	
48	EM801965	GASKET	1	
49	EM600000	COMPLETE TRANS. ASSY. ....	1	INCLUDES ITEMS W/#

**PAYMENT TERMS**

Terms of payment for parts are net 10 days.

**FREIGHT POLICY**

All parts orders will be shipped collect or prepaid with the charges added to the invoice. All shipments are F.O.B. point of origin. Multiquip's responsibility ceases when a signed manifest has been obtained from the carrier, and any claim for shortage or damage must be settled between the consignee and the carrier.

**MINIMUM ORDER**

The minimum charge for orders from Multiquip is \$15.00 net. Customers will be asked for instructions regarding handling of orders not meeting this requirement.

**RETURNED GOODS POLICY**

Return shipments will be accepted and credit will be allowed, subject to the following provisions:

1. A Returned Material Authorization must be approved by Multiquip prior to shipment.
2. To obtain a Return Material Authorization, a list must be provided to Multiquip Parts Sales that defines item numbers, quantities, and descriptions of the items to be returned.
  - a. The parts numbers and descriptions must match the current parts price list.
  - b. The list must be typed or computer generated.
  - c. The list must state the reason(s) for the return.
  - d. The list must reference the sales order(s) or invoice(s) under which the items were originally purchased.
  - e. The list must include the name and phone number of the person requesting the RMA.
3. A copy of the Return Material Authorization must accompany the return shipment.
4. Freight is at the sender's expense. All parts must be returned freight prepaid to Multiquip's designated receiving point.

5. Parts must be in new and resalable condition, in the original Multiquip package (if any), and with Multiquip part numbers clearly marked.
6. The following items are not returnable:
  - a. Obsolete parts. (If an item is in the price book and shows as being replaced by another item, it is obsolete.)
  - b. Any parts with a limited shelf life (such as gaskets, seals, "O" rings, and other rubber parts) that were purchased more than six months prior to the return date.
  - c. Any line item with an extended dealer net price of less than \$5.00.
  - d. Special order items.
  - e. Electrical components.
  - f. Paint, chemicals, and lubricants.
  - g. Decals and paper products.
  - h. Items purchased in kits.
7. The sender will be notified of any material received that is not acceptable.
8. Such material will be held for five working days from notification, pending instructions. If a reply is not received within five days, the material will be returned to the sender at his expense.
9. Credit on returned parts will be issued at dealer net price at time of the original purchase, less a 15% restocking charge.
10. In cases where an item is accepted, for which the original purchase document can not be determined, the price will be based on the list price that was effective twelve months prior to the RMA date.
11. Credit issued will be applied to future purchases only.

**PRICING AND REBATES**

Prices are subject to change without prior notice. Price changes are effective on a specific date and all orders received on or after that date will be billed at the revised price. Rebates for price declines and added charges for price increases will not be made for stock on hand at the time of any price change.

Multiquip reserves the right to quote and sell direct to Government agencies, and to Original Equipment Manufacturer accounts who use our products as integral parts of their own products.

**SPECIAL EXPEDITING SERVICE**

A \$35.00 surcharge will be added to the invoice for special handling including bus shipments, insured parcel post or in cases where Multiquip must personally deliver the parts to the carrier.

**LIMITATIONS OF SELLER'S LIABILITY**

Multiquip shall not be liable hereunder for damages in excess of the purchase price of the item with respect to which damages are claimed, and in no event shall Multiquip be liable for loss of profit or good will or for any other special, consequential or incidental damages.

**LIMITATION OF WARRANTIES**

No warranties, express or implied, are made in connection with the sale of parts or trade accessories nor as to any engine not manufactured by Multiquip. Such warranties made in connection with the sale of new, complete units are made exclusively by a statement of warranty packaged with such units, and Multiquip neither assumes nor authorizes any person to assume for it any other obligation or liability whatever in connection with the sale of its products. Apart from such written statement of warranty, there are no warranties, express, implied or statutory, which extend beyond the description of the products on the face hereof.


# PARTS AND OPERATION MANUAL

## **HERE'S HOW TO GET HELP**

PLEASE HAVE THE MODEL AND SERIAL  
NUMBER *ON-HAND* WHEN CALLING

### **UNITED STATES**

#### ***MULTIQUIP CORPORATE OFFICE***

18910 Wilmington Ave.  
Carson, CA 90746  
Contact: mq@multiquip.com

Tel. (800)-421-1244  
Fax (310)-537-3927

### **MEXICO**

#### ***MQ CIPSA***

Carr. Fed. Mexico-Puebla KM 126.5  
Momoxpan, Cholula, Puebla 72760 Mexico  
Contact: pmastretta@cipsa.com.mx

Tel. (52) 222-225-9900  
Fax (52) 222-285-0420

### **UNITED KINGDOM**

#### ***MULTIQUIP (UK) LIMITED HEAD OFFICE***

Hanover Mill, Fitzroy Street,  
Ashton-under-Lyne,  
Lancashire OL7 0TL  
Contact: kcassell@multiquip.com.uk

Tel. 0161 339 2223  
Fax 0161 339 3226

### **CANADA**

#### ***MULTIQUIP***

4110 Industriel Boul.  
Laval, Quebec, Canada H7L 6V3  
Contact: jmartin@multiquip.com

Tel. (450) 625-2244  
Fax (450) 625-8664

### **BRAZIL**

#### ***MULTIQUIP***

Av. Evandro Lins e Silva, 840 - grupo 505  
Barra de Tijuca - Rio de Janeiro  
RJ CEP 22631-470  
Contact: cnavarro@multiquip.com.br, srentes@multiquip.com.br

Tel. 011-55-21-3433-9055  
Fax 011-55-21-3433-9055

Your Local Dealer is:



#### ***MULTIQUIP (UK) LIMITED HEAD OFFICE***

Hanover Mill, Fitzroy Street,  
Ashton-under-Lyne,  
Lancashire OL7 0TL

Tel.: 0161 339 2223

Fax: 0161 339 3226

Contact: kcassell@multiquip.com.uk

Internet: multiquip.com